

AUTOGRAM
CORPORATION

Mini-Mix 8A

Mini-Mix 12A

AUDIO CONSOLE

INSTRUCTION MANUAL

AUTOGRAM MINI-MIX AUDIO CONSOLES

Mini-Mix 8A, Mini-Mix 12A

INSTRUCTION MANUAL

TABLE OF CONTENTS

Mini-Mix 8A Specification sheet.....	i.
Mini-Mix 8A Block Diagram	iii.
Mini-Mix 12A Specification sheet.....	iv.
Mini-Mix 12A Block Diagram	vi.
Autogram Product Warranty	vii.
Connection Warning	ix.
Section 1, Introduction	1.
Section 2, Installation	3.
Input Connections	4.
Output Connections	5.
Muting/Relay	6.
Remote Start Connections, Mini-Mix 8A	7.
Remote Start Connections, Mini-Mix 12A	8.
Mini-Mix 8A Cabling Run List	9.
Mini-Mix 12A Calling Run List	11.
List of Drawings	13.
Drawings	14.

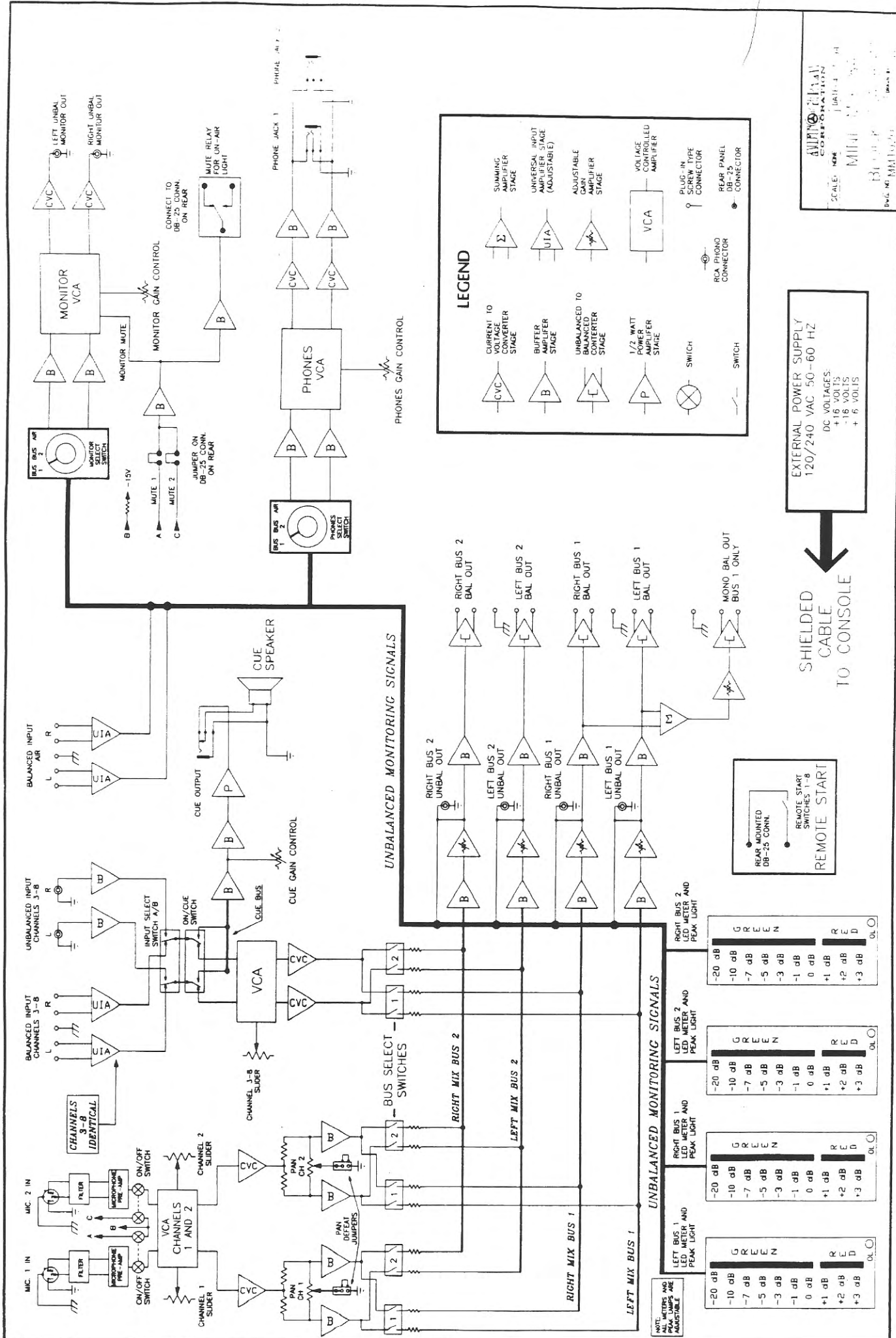

LEGEND

	CURRENT TO SOURCE FOLLOWER CHARACTER STAGE		UNIVERSAL INPUT AMPLIFIER STAGE (ADJUSTABLE)
	BUFFER AMPLIFIER STAGE		ADJUSTABLE GAIN AMPLIFIER STAGE
	UNBALANCED TO BALANCED CONVERTER STAGE		VOLTAGE CONTROLLED AMPLIFIER
	1/2 WATT POWER AMPLIFIER STAGE		SWITCH
	RCA PHONO CONNECTOR		PLUG-IN SCREW TYPE CONNECTOR
	DB-25 CONNECTOR		REAR PANEL CONNECTOR

EXTERNAL POWER SUPPLY
120/240 VAC 50-60 HZ
DC VOLTAGES:
+16 VOLTS
-16 VOLTS
+ 5 VOLTS

SHIELDED CABLE TO CONSOLE

REAR MOUNTED DB-25 CONN.
REMOTE START SWITCHES 1-8
REMOTE START

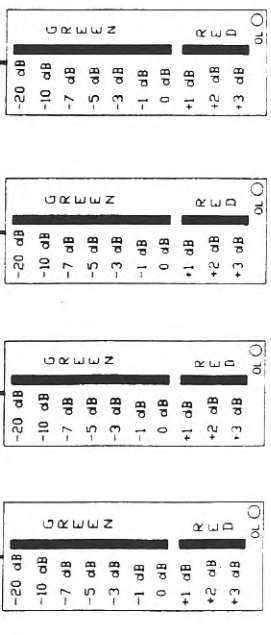

NOTE: GAINERS AND PHASERS ARE ADJUSTABLE

AVIATION COMMUNICATION CORPORATION
SCALE: NONE
DATE: 1-1-64
DRAWN BY: [illegible]
CHECKED BY: [illegible]

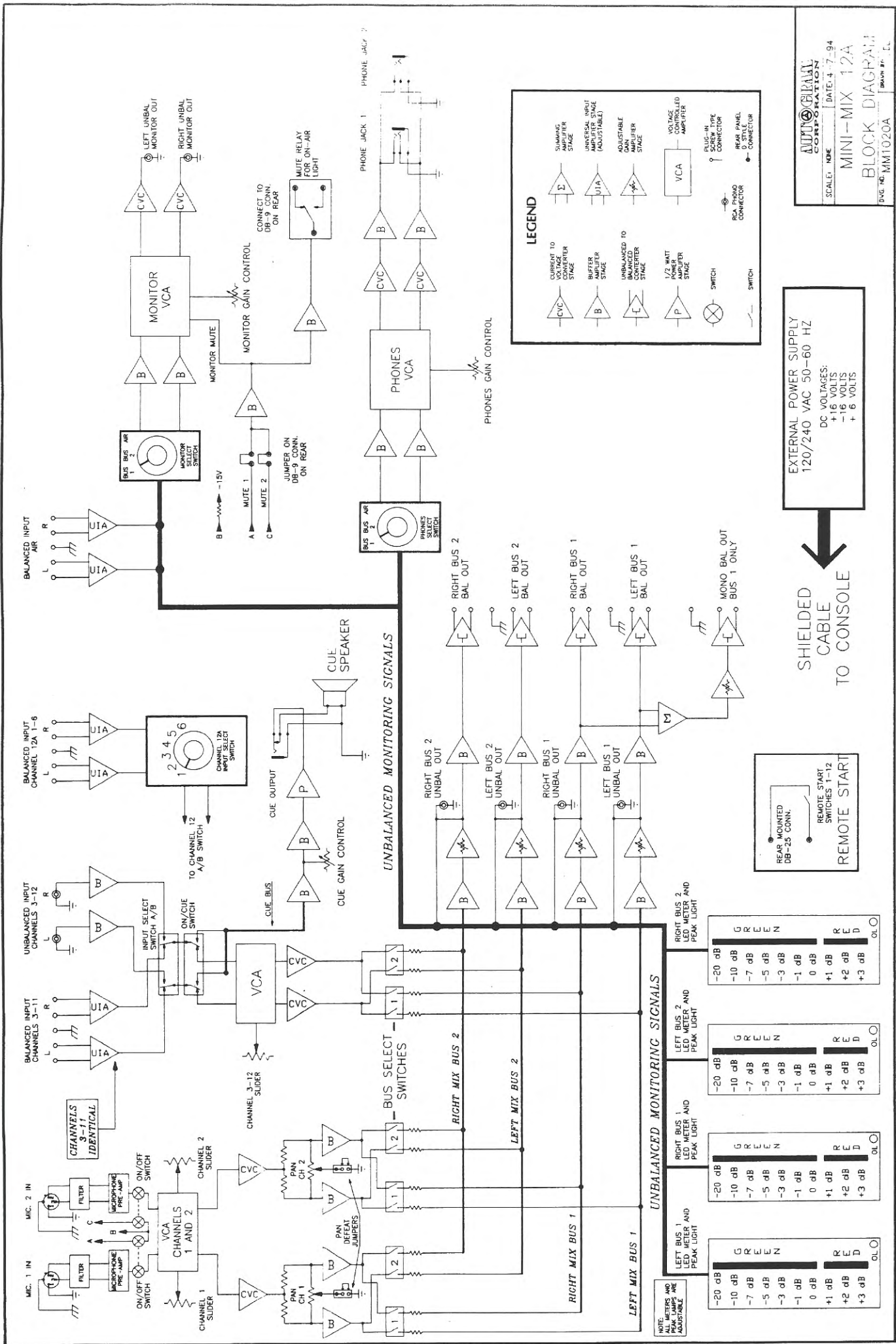

ADCO CORPORATION
 SCALE: NBE
 DATE: 4-7-94
MINI-MIX 12A
BLOCK DIAGRAM
 DWG. NO. MM1020A DRAWN BY: JL

EXTERNAL POWER SUPPLY
 120/240 VAC 50-60 HZ
 DC VOLTAGES:
 +16 VOLTS
 -16 VOLTS
 +6 VOLTS

SHIELDED
 CABLE
 TO CONSOLE

REAR MOUNTED
 DB-25 CONN.
 REMOTE START
 SWITCHES 1-12

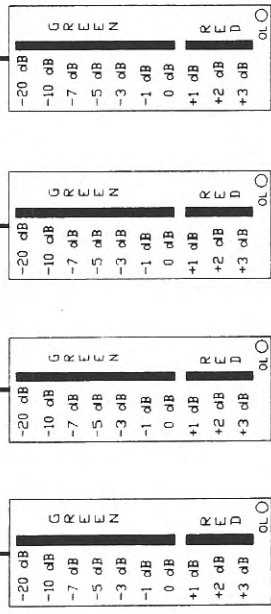

LEGEND

- CVC: CURRENT TO VOLTAGE CONVERTER STAGE
- B: BUFFER AMPLIFIER STAGE
- U: UNIVERSAL INPUT STAGE (ADJUSTABLE)
- A: ADJUSTABLE UNIVERSAL INPUT STAGE
- V: VOLTAGE LEADED AMPLIFIER STAGE
- P: 1/2 WATT POWER AMPLIFIER STAGE
- SW: SWITCH
- PLUG-IN SCREW TYPE CONNECTOR
- RCA PHONO CONNECTOR
- REAR PANEL 0 STYLE CONNECTOR

AUTOGRAM PRODUCT WARRANTY

Autogram warrants the original purchase of all products manufactured by Autogram Corporation and sold hereunder will, at the date of shipment, meet all published specifications and will be free from defects in design, workmanship, and material.

Warranties do not cover damage from lightning, floods, earthquakes, hurricanes, tornadoes, or acts of civil disobedience.

Warranties may not be honored when failure is caused by improper use or abuse, maintenance, repair or alteration by unauthorized persons.

Autogram agrees to repair or replace any equipment of its manufacture that fails to meet warranty conditions as set forth above for two (2) years from the date of invoice with the exception of lamps, fuses, and other expendable items. All major parts, such as VU Meters, Step Attenuators, Key Switches, etc., sold hereunder, which are not of Autogram Corporation manufacture, are sold subject to the warranty programs of the suppliers thereof.

In no event shall Autogram have any liability for consequential damages, loss, or expenses directly or indirectly arising from the use of the products, or any inability to use them either separately or in combination with other equipment or materials, or from any other cause.

Defective parts under warranty must be returned to Autogram per instructions. Parts replaced under warranty will be shipped freight prepaid by regular UPS or US Mail First Class. Any other method of shipment requested by the customer, such as air express, will be billed to the customer.

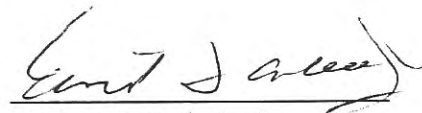

Ernest T. Ankele, Jr.

President

3/1/95

WARNING!

POWER CONNECTOR ON CONSOLE IS INVERTED FROM ALL OTHER MULTI-PIN CONNECTORS.

FAILURE TO INSTALL POWER CONNECTOR CORRECTLY WILL DAMAGE CONSOLE AND MAY VOID WARRANTY

CONSOLE CONNECTIONS

NOTE: POWER CONNECTOR IS INVERTED.

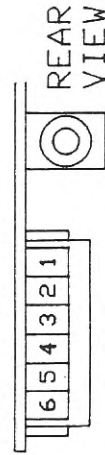

- 1 CHASSIS GROUND
- 2 -15 VDC
- 3 +15 VDC
- 4 +6 VDC (VDSP)
- 5 DIGITAL GROUND
- 6 AUDIO GROUND

POWER SUPPLY CONNECTIONS

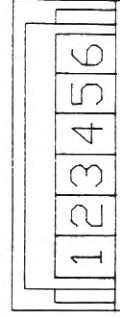

- 1 CHASSIS GROUND
- 2 -15 VDC
- 3 +15 VDC
- 4 +6 VDC (VDSP)
- 5 DIGITAL GROUND
- 6 AUDIO GROUND

AUTOGRAM MINI-MIX AUDIO CONSOLES

Mini-Mix 8A, Mini-Mix 12A

INSTRUCTION MANUAL

SECTION 1 INTRODUCTION

The Mini-Mix consoles are full-functioned professional broadcast audio mixing systems. Space and cost saving measures have yielded a small package along with an attractive price without giving up the features needed in today's active broadcast studio.

BASIC FEATURES

INPUT

The Mini-Mix consoles feature either eight or twelve channels: the first two are dedicated to microphones while the remaining channels provide 2 stereo inputs each (channel 12 on the Mini-Mix 12A has a total of 7 stereo inputs). Each channel may be assigned to either Mix Bus One and/or Mix Bus Two. Both buses may be fed simultaneously.

The slide faders operate with D.C. only and drive an associated V.C.A. (voltage controlled amplifier) for level control.

A unique feature of the Mini-Mix consoles is that the "A" input is an electrically-balanced professional-type while the "B" input uses PHONO-JACKS to be directly compatible with consumer-type equipment.

The balanced inputs use a miniature plug-in screw-type connector which makes installation very simple. Sources may be moved around easily for different configurations. Each balanced input is user-adjustable to accept levels between -15 dBv and +15 dBv. A balanced adjustable input is provided for connecting an external air-monitor source.

The microphone inputs use convenient XLR type connectors and feature PAN POTS. The pan pots may be disabled if this feature is not desired. A front panel switch turns the microphone channel ON and OFF while activating the "Mute" circuit when the channel is "on". The muting may be programmed for either microphone channel.

OUTPUT

Balanced and unbalanced outputs are provided for the two mixing buses. As with the inputs, the balanced outputs use miniature plug-in screw-type connectors while the unbalanced outputs use phono jacks.

A balanced output is provided for the MONO sum of Mix bus 1.

MONITORING

Separate select switches and level controls are provided for the headphone and monitor circuits. Bus 1, Bus 2, or an external Air signal may be selected. An external monitor power amplifier is required which may be whatever power range desired. The monitor driver output is on phono jacks and is compatible with consumer type amplifiers. Muting for the monitor output is included and may be programmed to operate from either microphone channel. The headphone outputs appear on two standard 1/4 inch phone jacks and are designed to accommodate modern higher impedance headphones with ample volume.

A cue speaker and amplifier are built-in to provide cue monitoring. A front panel switch on non-microphone channels select CUE. When CUE is selected, that channel will be removed from the output buses.

METERING

Four LED bar graphs provide visual indication of output level for the Left and Right channels of Bus 1 and Bus 2. A special circuit enables the graphs to respond with "ballistics" which are similar to the standard Vu meter. Additional LEDs are used to give indication of an Overload condition (10 dB above 0 reference, adjustable) and are designed to give fast response to audio peaks.

OTHER FEATURES

Front edge switches provide dry contacts which can be used for remote starting equipment or for other purposes. Connection for the switches is on a rear mounted Sub-D type connector.

An internal relay is included to activate On-Air lights and may be programmed to either microphone channel. The relay follows the monitor muting assignments.

A small jack is provided to give access to the cue output. When a plug is inserted into the jack, the internal cue speaker will be disabled.

SECTION 2

INSTALLATION

The Mini-Mix consoles are small enough to be installed in almost any location and may be used in permanent as well as temporary situations. The Mini-Mix consoles can be used at remote sites and in remote vehicles.

POWER SUPPLY CONNECTIONS

The Mini-Mix power supply can be mounted up to eight feet from the console. A shielded interface cable is provided for this purpose. Unless requested, the power supply is wired for 115 v.a.c./ 60hz mains. The transformer can be rewired for 230 v.a.c./ 50hz mains.

BEFORE APPLYING POWER

Connect each end of the shielded power supply cable.

*** THE CONNECTOR AT THE CONSOLE END IS INVERTED AND WILL ***
*** PLUG IN UPSIDE DOWN. ***

*FAILURE TO INSTALL POWER CONNECTOR CORRECTLY WILL
DAMAGE CONSOLE AND MAY VOID WARRANTY*

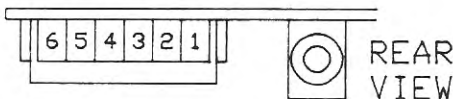
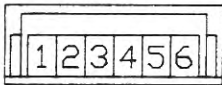
CONSOLE CONNECTIONS	POWER SUPPLY CONNECTIONS
<i>NOTE: POWER CONNECTOR IS INVERTED.</i>	
	
1 CHASSIS GROUND	1 CHASSIS GROUND
2 -15 VDC	2 -15 VDC
3 +15 VDC	3 +15 VDC
4 +6 VDC (VDSP)	4 +6 VDC (VDSP)
5 DIGITAL GROUND	5 DIGITAL GROUND
6 AUDIO GROUND	6 AUDIO GROUND

WARNING: DO NOT ALLOW ANYTHING TO FALL INTO VENT OPENINGS!

Connect the IEC power cord to the proper outlet and the power supply IEC filter. The power switch may now be turned on.

POWER CABLE PIN-OUT

PIN	FUNCTION	WIRE COLOR
1	CHASSIS GROUND	GREEN
1	(POWER SUPPLY END ONLY)	SHIELD
2	- 15 VOLTS DC	WHITE
3	+ 15 VOLTS DC	RED
4	+ 6 VOLTS DC	ORANGE
5	DIGITAL GROUND	BLUE
6	ANALOG GROUND	BLACK

MICROPHONE CONNECTIONS

Any standard balanced low-impedance microphone may be used with the Mini-Mix console; however, the preamplifiers are optimized for 150 ohm source impedances. Pin 3 on the XLR connector is considered high or + while pin 2 is low or -. Pin 1 is ground. An unbalanced microphone can be used by wiring the center conductor to pin 3 and the shield to pin 1.

PAN POTS

The pan pots are used to adjust the position of the microphone sound in the stereo image. Turn the pot to the left to make the microphone appear to the left; turn the pot to the right to position the sound to the right. This feature is useful for interviews where the interviewer might appear on the left channel and the subject on the right.

To DISABLE the pan pot, remove the screws along the underside of the front panel lip. The front panel can then be raised up (it is hinged at the rear). There are jumper-headers located near each microphone pre-amplifier (refer to main parts layout drawing MM1021). Simply move the jumper to the other pin or just remove the jumper.

Muting of the monitor and the mute relay will be covered later.

BALANCED INPUT CONNECTIONS

(Refer to drawing at the end on this section for connector hookup.)

Balanced professional equipment can be connected to the plug-in screw-type connectors on the non-microphone. Levels between -15 dBv and +15 dBv may be accommodated. The inputs are 20k ohm bridging. If a terminated input is required, a 600 ohm resistor must be placed on the connector along with the wiring for both left and right channels. To connect a mono source, simply connect to the left channel then jumper to the right channel.

BALANCED CONNECTIONS

PIN 1	+ LEFT CHANNEL
PIN 2	- LEFT CHANNEL
PIN 3	GROUND
PIN 4	+ RIGHT CHANNEL
PIN 5	- RIGHT CHANNEL

***Note: Pin 1 is on the left side looking at console rear.

After the sources are connected, the levels may be trimmed by means of the small pots which are located on either side of the balanced input connector and are accessible through the respective small holes. A 3/32 inch "Greenie" screwdriver works nicely for adjusting the Mini-Mix input levels.

UNBALANCED INPUT CONNECTIONS

Connect consumer-type equipment directly to the phono-jack inputs. No adjustments are required.

OUTPUT CONNECTIONS

BUS 1 AND BUS 2 MAIN OUTPUT CONNECTIONS

DO NOT GROUND + OR - OUTPUT CONNECTIONS

(Refer to drawing at the end on this section for connector hookup.)

The balanced outputs for the Mini-Mix consoles are calibrated at the factory for +8 dBm into a 600 ohm load. The actual output impedance is approximately 100 ohms. Internal master gain controls allow the output to be adjusted to another reference value; however, the metering system will require re-calibration if these levels are changed. Do not ground either + or - output terminal. If an unbalanced feed is required, use the + terminal and ground.

BALANCED CONNECTIONS

PIN 1	+ LEFT CHANNEL
PIN 2	- LEFT CHANNEL
PIN 3	GROUND
PIN 4	+ RIGHT CHANNEL
PIN 5	- RIGHT CHANNEL

***Note: Pin 1 is on the left side looking at console rear.

MONO OUTPUT

The balanced MONO output provides the monaural sum of Bus 1. The output characteristics are identical to the main bus outputs. A level control is located adjacent to the connector.

TELEPHONE INTERFACE

The MONO output may be used for interfacing to a telephone system. In this case use Bus 2 as the main output and use Bus 1 as an assignable MIX-MINUS output. Do not ground either + or - output terminal. If an unbalanced feed is required, use the + terminal and ground.

A telephone interface unit is required to connect the console to the telephone line.

MONO CONNECTIONS

PIN 1	GROUND
PIN 2	- OUTPUT
PIN 3	+ OUTPUT

UNBALANCED OUTPUT CONNECTIONS

Unbalanced outputs are provided for BUS 1, BUS 2, and MONITOR. These outputs will interface directly to consumer type equipment.

CUE

While a cue speaker is built in, it may be desirable to employ a larger speaker or a more powerful external amplifier and speaker. An 1/8 inch mini-phone jack is provided to allow access to the cue amplifier output. When a plug is inserted into this jack, the internal cue speaker will be disconnected. The level will still be adjusted by the CUE GAIN control.

AUXILIARY FUNCTIONS

MUTING ASSIGNMENTS

Muting for the MONITOR output as well as activation of the mute relay can be programmed to operate from either microphone channel.

The Sub-D male connector (supplied) must be inserted into the proper connector on the rear panel to allow muting. The connector is factory wired to provide muting for both microphones. Refer to the wiring tables if a different configuration is required.

MUTE RELAY CONNECTIONS

Contacts for the MUTE RELAY are brought out to the REMOTE START connector on the rear panel. These contacts can be used to activate an ON AIR light. Refer to the wiring tables for connection information.

CAUTION

THE RELAY CONTACTS ARE RATED FOR 1 AMP D.C. AND 25 WATTS A.C ONLY. IF LARGER LAMPS ARE TO BE USED AN EXTERNAL CONTROLLER MUST BE USED.

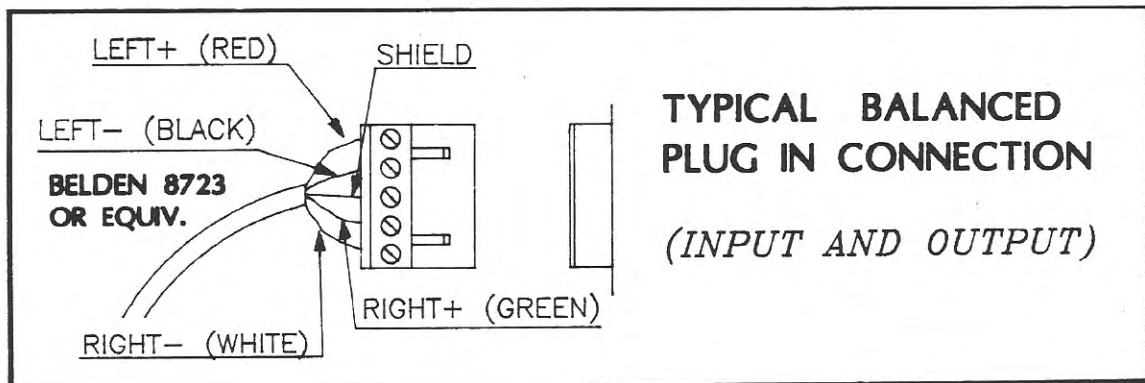

AUXILIARY CONNECTIONS
 Mini-Mix 8A
 J35 REMOTE STARTS (DB25 CONNECTOR ON REAR PANEL)
 WIRING TABLE 1

FUNCTION	PINS
Remote Start Switch #1	1 and 14
Remote Start Switch #2	2 and 15
Remote Start Switch #3	3 and 16
Remote Start Switch #4	4 and 17
Remote Start Switch #5	5 and 18
Remote Start Switch #6	6 and 19
Remote Start Switch #7	7 and 20
Remote Start Switch #8	8 and 21

RELAY/MUTE

MUTE RELAY COMMON	23
MUTE RELAY NORMALLY CLOSED	11
MUTE RELAY NORMALLY OPEN	10
Mute Microphone Channel 1	12 and 24 (Jumper)
Mute Microphone Channel 2	13 and 25 (Jumper)

Note: Both microphone channels are factory assigned to mute.
 * REMOVE JUMPER TO DISABLE MUTING *

AUXILIARY CONNECTIONS
 Mini-Mix 12A
 J35 REMOTE STARTS (DB25 CONNECTOR ON REAR PANEL)
 WIRING TABLE 2

FUNCTION	PINS
Remote Start Switch 1	1 and 14
Remote Start Switch 2	2 and 15
Remote Start Switch 3	3 and 16
Remote Start Switch 4	4 and 17
Remote Start Switch 5	5 and 18
Remote Start Switch 6	6 and 19
Remote Start Switch 7	7 and 20
Remote Start Switch 8	8 and 21
Remote Start Switch 9	9 and 22
Remote Start Switch 10	10 and 23
Remote Start Switch 11	11 and 24
Remote Start Switch 12	12 and 25

AUXILIARY CONNECTIONS
 Mini-Mix 12A
 J36 RELAY/MUTE (DB9 CONNECTOR ON REAR PANEL)
 WIRING TABLE 3

MUTE RELAY COMMON	6
MUTE RELAY NORMALLY CLOSED	2
MUTE RELAY NORMALLY OPEN	1
Mute Microphone Channel 1	5 and 9 (Jumper)
Mute Microphone Channel 2	4 and 8 (Jumper)

Note: Both microphone channels are factory assigned to mute.
 * REMOVE JUMPER TO DISABLE MUTING *

MINI-MIX 8A CABLING RUN LIST

(J35) DB-25 FEMALE REMOTE START CONNECTOR

PIN	#	COLOR	LENGTH	FUNCTION	TO
1	X	GRN		REMOTE START 1+	SW1 PIN 1
14	X	WHT/GRN		REMOTE START 1-	SW1 PIN 3
2	X	BLU		REMOTE START 2+	SW2 PIN 1
15	X	WHT/BLU		REMOTE START 2-	SW2 PIN 3
3	X	YEL		REMOTE START 3+	SW3 PIN 1
16	X	WHT/YEL		REMOTE START 3-	SW3 PIN 3
4	X	VIO		REMOTE START 4+	SW4 PIN 1
17	X	WHT/VIO		REMOTE START 4-	SW4 PIN 3
5	X	BRN		REMOTE START 5+	SW5 PIN 1
18	X	WHT/BRN		REMOTE START 5-	SW5 PIN 3
6	X	ORG		REMOTE START 6+	SW6 PIN 1
19	X	WHT/ORG		REMOTE START 6-	SW6 PIN 3
7	X	GRY		REMOTE START 7+	SW7 PIN 1
20	X	WHT/GRY		REMOTE START 7-	SW7 PIN 3
8	X	BLK		REMOTE START 8+	SW8 PIN 1
21	X	WHT/BLK		REMOTE START 8-	SW8 PIN 3

RELAY CONNECTIONS

10	282	RED	RELAY N.O.	P/J15 PIN 4
11	282	GRN	RELAY N.C.	P/J15 PIN 3
23	282	WHT	RELAY COMMON	P/J15 PIN 2
X	282	BLK	X	P/J15 PIN 1

MUTE CONNECTIONS

12	283	RED	MUTE 1	P/J4 PIN 1
13	283	GRN	MUTE 2	P/J4 PIN 2
NC	283	SHIELD		P/J4 PIN 3
24	283	BLK	MUTE 3	P/J4 PIN 4
25	283	WHT	MUTE 4	P/J4 PIN 5

MICROPHONE CONNECTORS

MIC. 1 CONNECTOR (MJ1)

PIN	#	COLOR	FUNCTION	TO
3	285	RED	MIC. 1 +	P/J13 PIN 2
2	285	BLK	MIC. 1 -	P/J13 PIN 3
1	285	SHIELD	MIC. 1 GND	P/J13 PIN 1
G	285	GRN	MIC. 1 SHELL	P/J13 PIN 4

MIC. 2 CONNECTOR (MJ2)

PIN	#	COLOR	FUNCTION	TO
3	284	RED	MIC. 2 +	P/J14 PIN 2
2	284	BLK	MIC. 2 -	P/J14 PIN 3
1	284	SHIELD	MIC. 2 GND	P/J14 PIN 1
G	284	GRN	MIC. 2 SHELL	P/J14 PIN 4

MINI-MIX 8A CABLING RUN LIST
CONTD.

CUE GAIN CONTROL

PIN	#	COLOR	FUNCTION	TO
1	286	RED	CUE GAIN INPUT	P/J16 PIN 4
2	286	GRN	CUE GAIN OUTPUT	P/J16 PIN 3
3	286	BLK	CUE GAIN COMMON	P/J16 PIN 2
NC	286	SHIELD	SHIELD	P/J16 PIN 4

CUE SPEAKER/OUTPUT JACK WIRING

CUE JACK

1	287	RED	CUE AMP OUTPUT	P/J18 PIN 1
1	287	BLK	CUE AMP OUTPUT	P/J18 PIN 2
2	X	ORG	CUE SPEAKER+	SPKR 1
3	X	WHT/ORG	CUE SPEAKER-	SPKR 2
3	287	GRN	CUE AMP GND	P/J18 PIN 4
NC	287	SHIELD	SHIELD	P/J18 PIN 5

HEADPHONE JACK WIRING

HJ2 (NEAREST CHANNEL 8)

1	288	RED	LEFT HEADPHONE OUT	P/J7 PIN 2
2	288	GRN	RIGHT HEADPHONE OUT	P/J17 PIN 1
3	288	BLK	LEFT GND	P/J17 PIN 3
3	288	WHT	RIGHT GND	P/J17 PIN 4

JUMPER TO HJ1 NEAREST CHANNEL 1

HJ1

1	289	RED	LEFT HEADPHONE	HJ2 PIN 1
2	289	GRN	RIGHT HEADPHONE	HJ2 PIN 2
3	289	BLK	LEFT GND	HJ2 PIN 3
3	289	WHT	RIGHT GND	HJ2 PIN 3

MINI-MIX 12A CABLING RUN LIST

(J35) FEMALE DB-25 REMOTE START CONNECTOR

PIN	#	COLOR	LENGTH	FUNCTION	TO
1	272	GRN		REMOTE START 1+	SW1 PIN 1
14	272	WHT		REMOTE START 1-	SW1 PIN 2
2	272	BLU		REMOTE START 2+	SW2 PIN 1
15	272	GRY		REMOTE START 2-	SW2 PIN 2
3	272	YEL		REMOTE START 3+	SW3 PIN 1
16	272	TAN		REMOTE START 3-	SW3 PIN 2
4	272	VIO		REMOTE START 4+	SW4 PIN 1
17	272	PNK		REMOTE START 4-	SW4 PIN 2
5	272	BRN		REMOTE START 5+	SW5 PIN 1
18	272	BLK		REMOTE START 5-	SW5 PIN 2
6	272	ORG		REMOTE START 6+	SW6 PIN 1
19	272	RED		REMOTE START 6-	SW6 PIN 2
7	273	GRN		REMOTE START 7+	SW7 PIN 1
20	273	WHT		REMOTE START 7-	SW7 PIN 2
8	273	BLU		REMOTE START 8+	SW8 PIN 1
21	273	GRY		REMOTE START 8-	SW8 PIN 2
9	273	YEL		REMOTE START 9+	SW3 PIN 1
22	273	TAN		REMOTE START 9-	SW3 PIN 2
10	273	VIO		REMOTE START 10+	SW4 PIN 1
23	273	PNK		REMOTE START 10-	SW4 PIN 2
11	273	BRN		REMOTE START 11+	SW5 PIN 1
24	273	BLK		REMOTE START 11-	SW5 PIN 2
12	273	ORG		REMOTE START 12+	SW6 PIN 1
25	273	RED		REMOTE START 12-	SW6 PIN 2

J36 DB-9 RELAY/MUTE FEMALE CONNECTIONS

10	266	RED	RELAY N.O.	P/J15 PIN 4
11	266	GRN	RELAY N.C.	P/J15 PIN 3
23	266	WHT	RELAY COMMON	P/J15 PIN 2
3	266	BLK	X	P/J15 PIN 1

MUTE CONNECTIONS

12	267	RED	MUTE 1	P/J4 PIN 1
13	267	GRN	MUTE 2	P/J4 PIN 2
NC	267	SHIELD		P/J4 PIN 3
24	267	BLK	MUTE 3	P/J4 PIN 4
25	267	WHT	MUTE 4	P/J4 PIN 5

MINI-MIX 12A CABLING RUN LIST
CONTD.

MICROPHONE CONNECTORS

MIC. 1 CONNECTOR (MJ1)

PIN #	COLOR	FUNCTION	TO
3	285 RED	MIC. 1 +	P/J13 PIN 2
2	285 BLK	MIC. 1 -	P/J13 PIN 3
1	285 SHIELD	MIC. 1 GND	P/J13 PIN 1
G	285 GREEN	MIC. 1 SHELL	P/J13 PIN 4

MIC. 2 CONNECTOR (MJ2)

PIN #	COLOR	FUNCTION	TO
3	284 RED	MIC. 2 +	P/J14 PIN 2
2	284 BLK	MIC. 2 -	P/J14 PIN 3
1	284 SHIELD	MIC. 2 GND	P/J14 PIN 1
G	284 GREEN	MIC. 2 SHELL	P/J14 PIN 4

CUE GAIN CONTROL

PIN #	COLOR	FUNCTION	TO
1	274 RED	CUE GAIN INPUT	P/J16 PIN 4
2	274 GRN	CUE GAIN OUTPUT	P/J16 PIN 3
3	274 BLK	CUE GAIN COMMON	P/J16 PIN 2
NC	274 SHIELD	SHIELD	P/J16 PIN 4

CUE SPEAKER/OUTPUT JACK WIRING

CUE JACK		FUNCTION	TO
1	287 RED	CUE AMP OUTPUT	P/J18 PIN 1
1	287 BLK	CUE AMP OUTPUT	P/J18 PIN 2
2	X ORG	CUE SPEAKER+	SPKR 1
3	X WHT/ORG	CUE SPEAKER-	SPKR 2
3	287 GRN	CUE AMP GND	P/J18 PIN 4
NC	287 SHIELD	SHIELD	P/J18 PIN 5

HEADPHONE JACK WIRING

HJ2 (NEAREST CHANNEL 12)

		FUNCTION	TO
1	288 RED	LEFT HEADPHONE	P/J7 PIN 2
2	288 GRN	RIGHT HEADPHONE	P/J17 PIN 1
3	288 BLK	LEFT GND	P/J17 PIN 3
3	288 WHT	RIGHT GND	P/J17 PIN 4

JUMPER TO HJ1 NEAREST CHANNEL 1

HJ1

		FUNCTION	TO
1	289 RED	LEFT HEADPHONE	HJ2 PIN 1
2	289 GRN	RIGHT HEADPHONE	HJ2 PIN 2
3	289 BLK	LEFT GND	HJ2 PIN 3
3	289 WHT	RIGHT GND	HJ2 PIN 3

LIST OF DRAWINGS

- #1 MM1003 MINI-MIX 8A & 12A MAIN BOARD SCHEMATIC, PAGE 1
- #2 MM1004 MINI-MIX 8A & 12A MAIN BOARD SCHEMATIC, PAGE 2
- #3 MM1005 MINI-MIX 8A & 12A BALANCED BOARD SCHEMATIC
- #4 MM1006 MINI-MIX 8A & 12A METER BOARD SCHEMATIC
- #5 MM1008 MINI-MIX 8A & 12A POWER SUPPLY SCHEMATIC
- #6 MM1021 MINI-MIX 8A & 12A PC BOARD PARTS LOCATION
MAIN BOARD, BALANCED BOARD, METER BOARD
- #7 MM1201 MINI-MIX 12A MAIN EXTENSION BOARD SCHEMATIC
- #8 MM1202 MINI-MIX 12A BALANCED EXTENSION AND MULTILINE
BOARDS SCHEMATIC
- #9 MM1204 MINI-MIX 12A PC BOARD PARTS LOCATION
MAIN BOARD EXT., BALANCED BOARD EXT., MULTILINE
BOARD

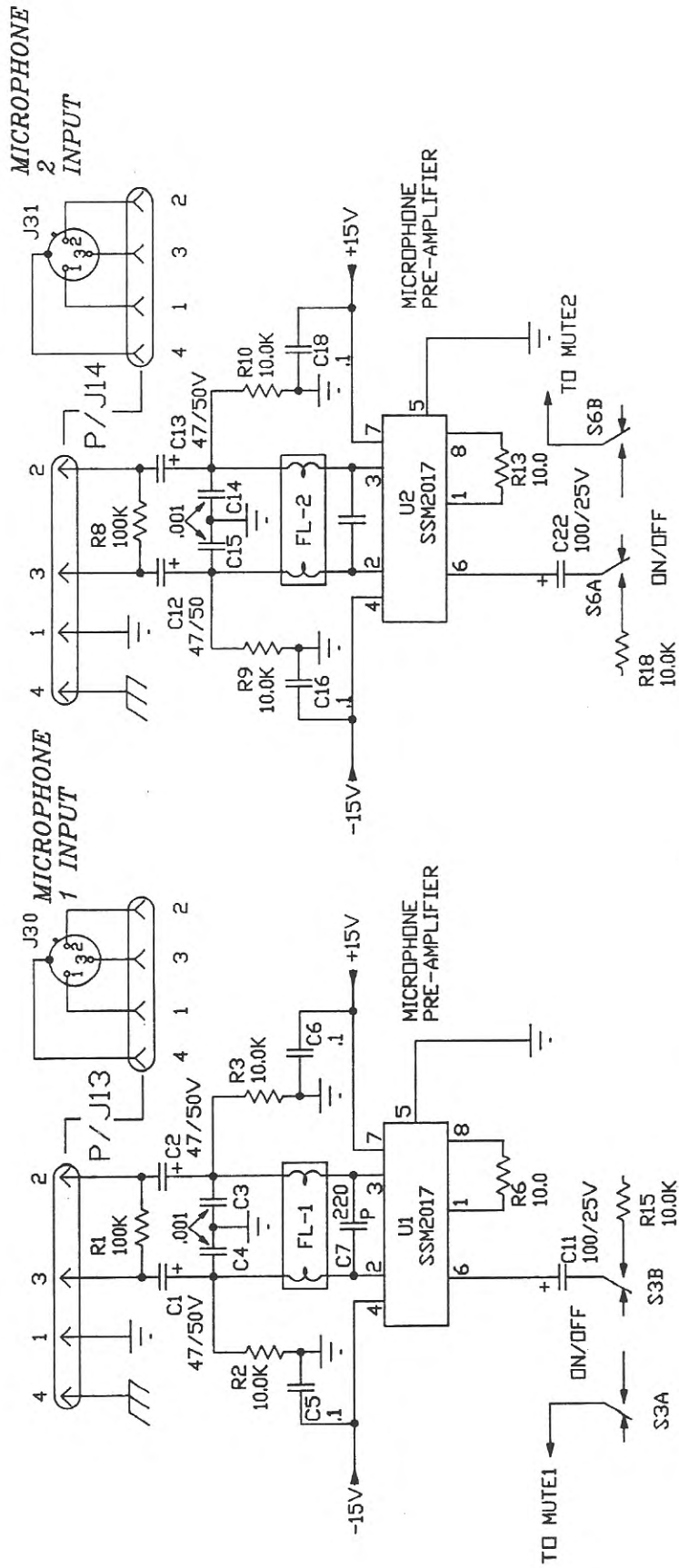

AUTOCORAM
CORPORATION

12-10-96

MINI-MIX MODIFICATION TO CHANGE
MIC. PRE-AMP TO SSM2017 DEVICE

AUTGRAM

MODIFICATION TO MINIMIX CONSOLE
TO CONVERT STEREO BALANCED LINE INPUT
TO MONO MICROPHONE LEVEL INPUT

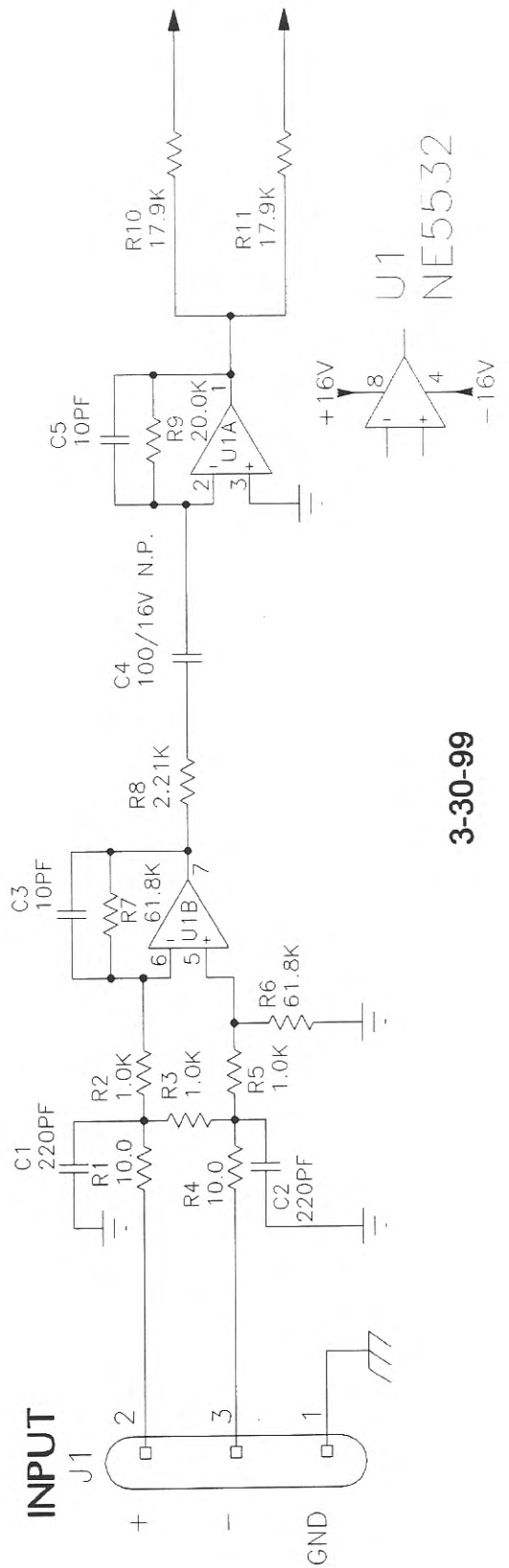

3-30-99

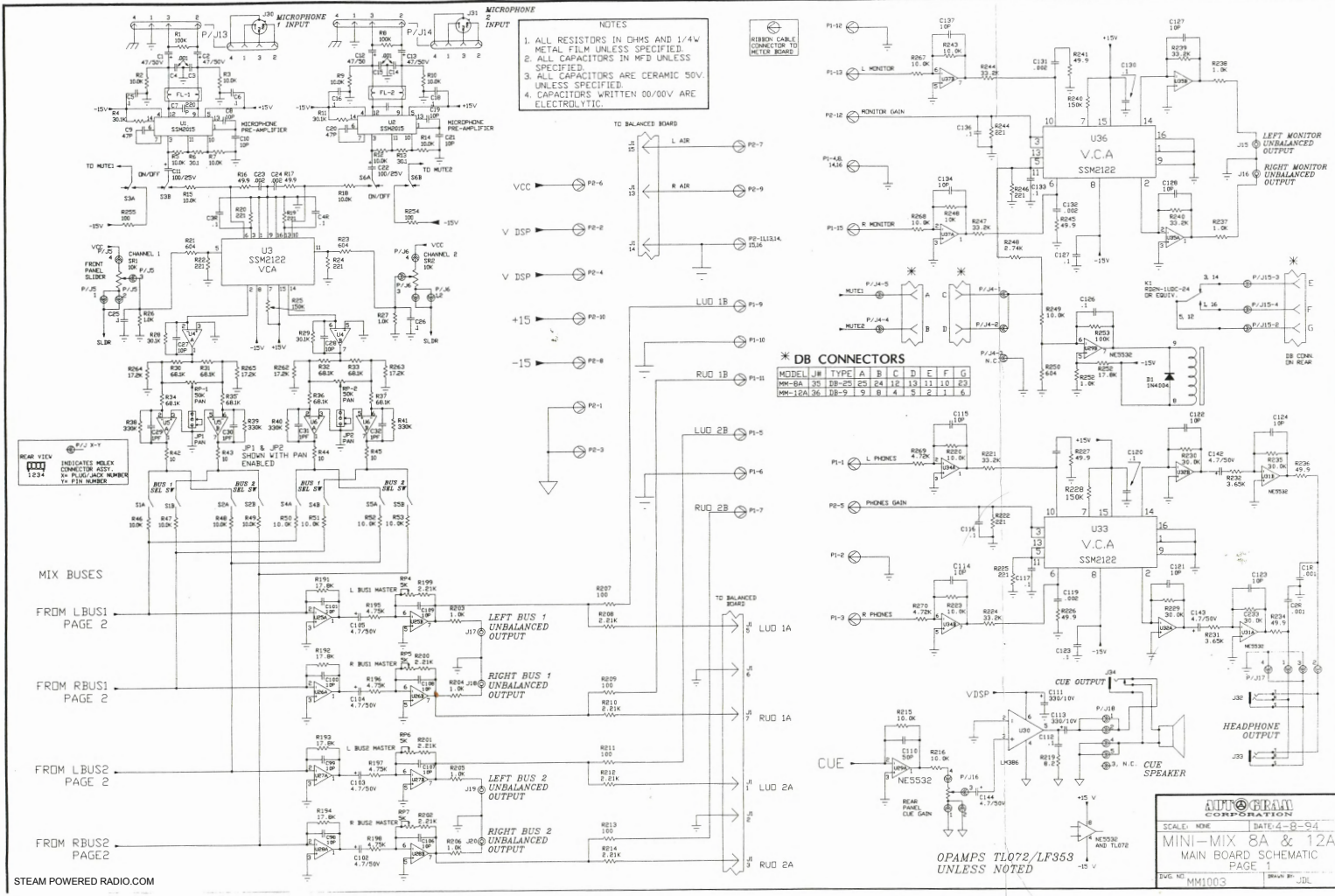

- NOTES**
1. ALL RESISTORS IN OHMS AND 1/4W METAL FILM UNLESS SPECIFIED.
 2. ALL CAPACITORS IN MFD UNLESS SPECIFIED.
 3. ALL CAPACITORS ARE CERAMIC 50V UNLESS SPECIFIED.
 4. CAPACITORS WRITTEN 00/00V ARE ELECTROLYTIC.

① RIBBON CABLE CONNECTOR TO MIXER BOARD

*** DB CONNECTORS**

MODEL	JW	TYPE	A	B	C	D	E	F	G
MM-6A	38	DP-25	23	24	12	13	11	10	20
MM-12A/16	DP-9	9	8	4	5	2	1	1	6

AMPHIPHAN CORPORATION
 SCALE: NONE DATE: 4-8-94
MINI-MIX 8A & 12A
 MAIN BOARD SCHEMATIC
 PAGE 1
 SHEET NO. MM1003 DRAWN BY: JDL

AIR MONITOR

CH 8

CH 7

CH 6

CH 5

CH 4

CH 3

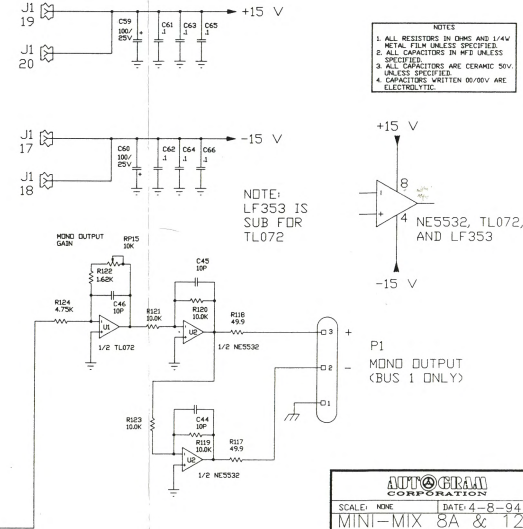
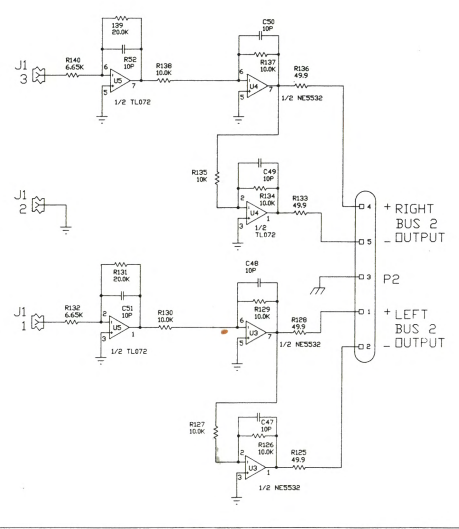
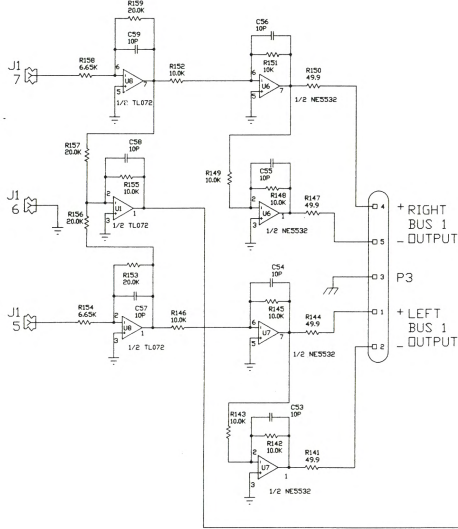
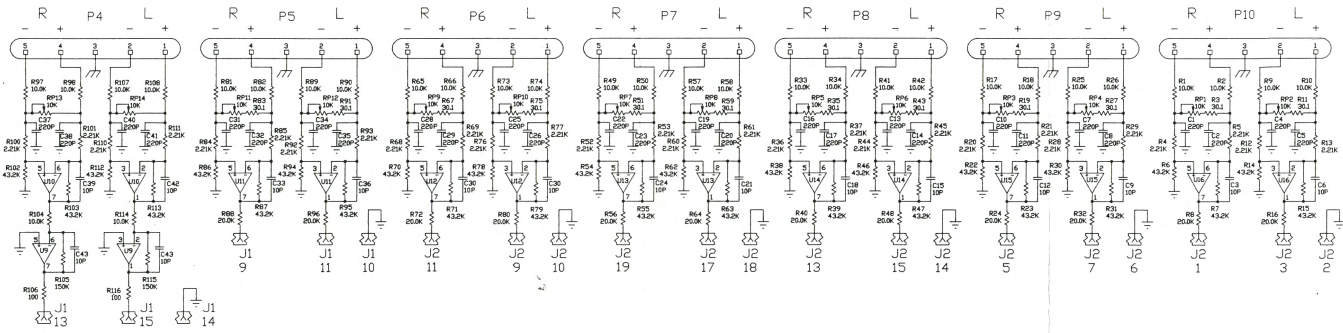

- NOTES
1. ALL RESISTORS IN OHMS AND 1/4W METAL FILM UNLESS SPECIFIED.
 2. ALL CAPACITORS IN PFD UNLESS SPECIFIED.
 3. UNLESS SPECIFIED, ALL CAPACITORS ARE CERAMIC 50V.
 4. CAPACITORS WRITTEN 00/10V ARE ELECTROLYTIC.

NOTE: LF353 IS SUB FOR TL072

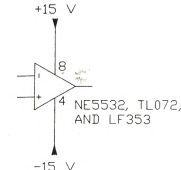

ADP-CORPORATION
 SCALE: NONE DATE: 4-8-94
 MINI-MIX 8A & 12A
 BALANCED BOARD
 SCHEMATIC
 REV: NE MM1015 JDL

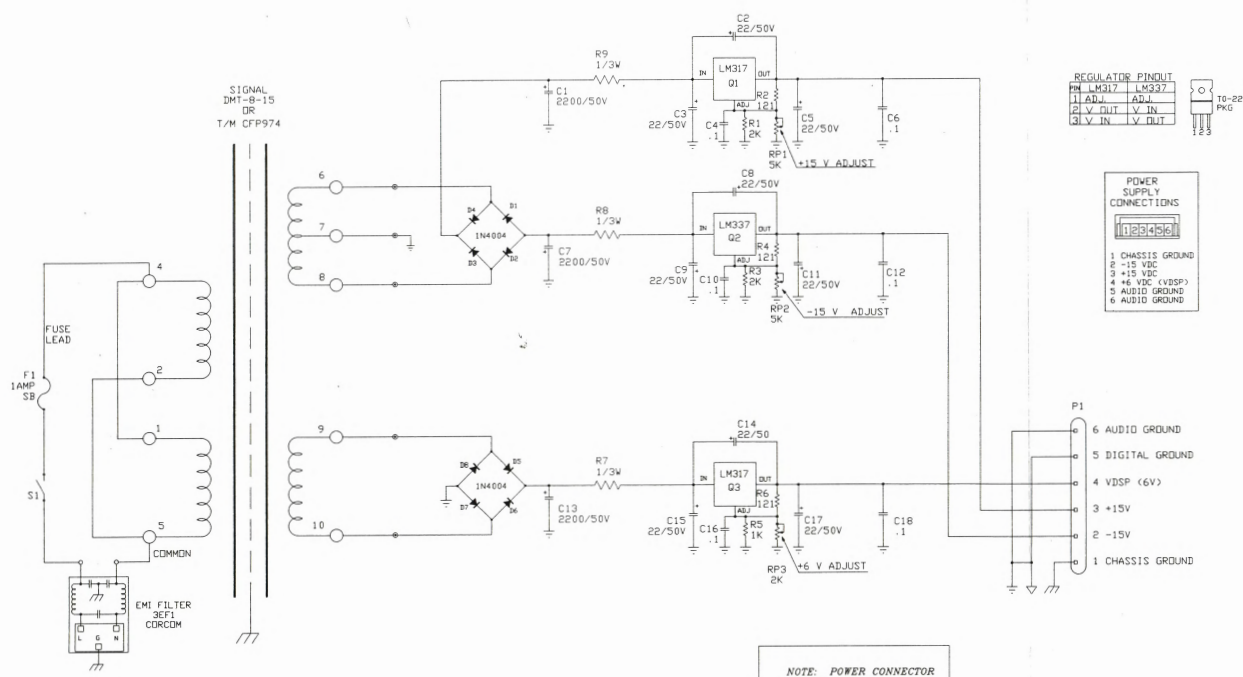

REGULATOR PINOUT

1	LM317	LM337
1	ADJ.	ADJ.
2	V. OUT	V. IN
3	V. IN	V. OUT

10-220 PKG

POWER SUPPLY CONNECTIONS

1	CHASSIS GROUND
2	-15 VDC
3	+15 VDC
4	+6 VDC (VBSP)
5	AUDIO GROUND
6	AUDIO GROUND

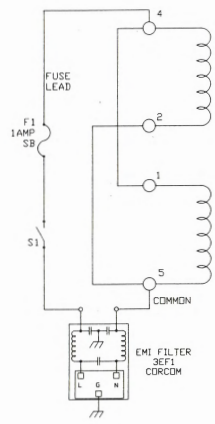

TRANSFORMER SHOWN WIRED FOR 117VAC

FOR 220 VOLT OPERATION:
CONNECT FUSE LEAD TO PIN 1,
CONNECT COMMON TO PIN 5,
JUMPER PINS 2 AND 4.

- NOTES
1. ALL RESISTORS IN OHMS AND 1/4W METAL FILM UNLESS SPECIFIED.
 2. ALL CAPACITORS IN MFD UNLESS SPECIFIED.
 3. ALL CAPACITORS ARE CERAMIC 50V, UNLESS SPECIFIED.
 4. CAPACITORS WRITTEN 00/00V ARE ELECTROLYTIC.

NOTE: POWER CONNECTOR IS INVERTED.

REAR VIEW

1	CHASSIS GROUND
2	-15 VDC
3	+15 VDC
4	+6 VDC (VBSP)
5	AUDIO GROUND
6	AUDIO GROUND

CONSOLE CONNECTION

WARNING
POWER CONNECTOR ON CONSOLE IS INVERTED FROM ALL OTHER CONNECTORS.

ADMM CORPORATION
CIRCLE 20 MAGAZINE

SCALE: NONE DATE: 4-11-94

MINI-MIX 8A & 12A
POWER SUPPLY SCHEMATIC

REV: 10 MM1.00B DRAWN BY: JDL

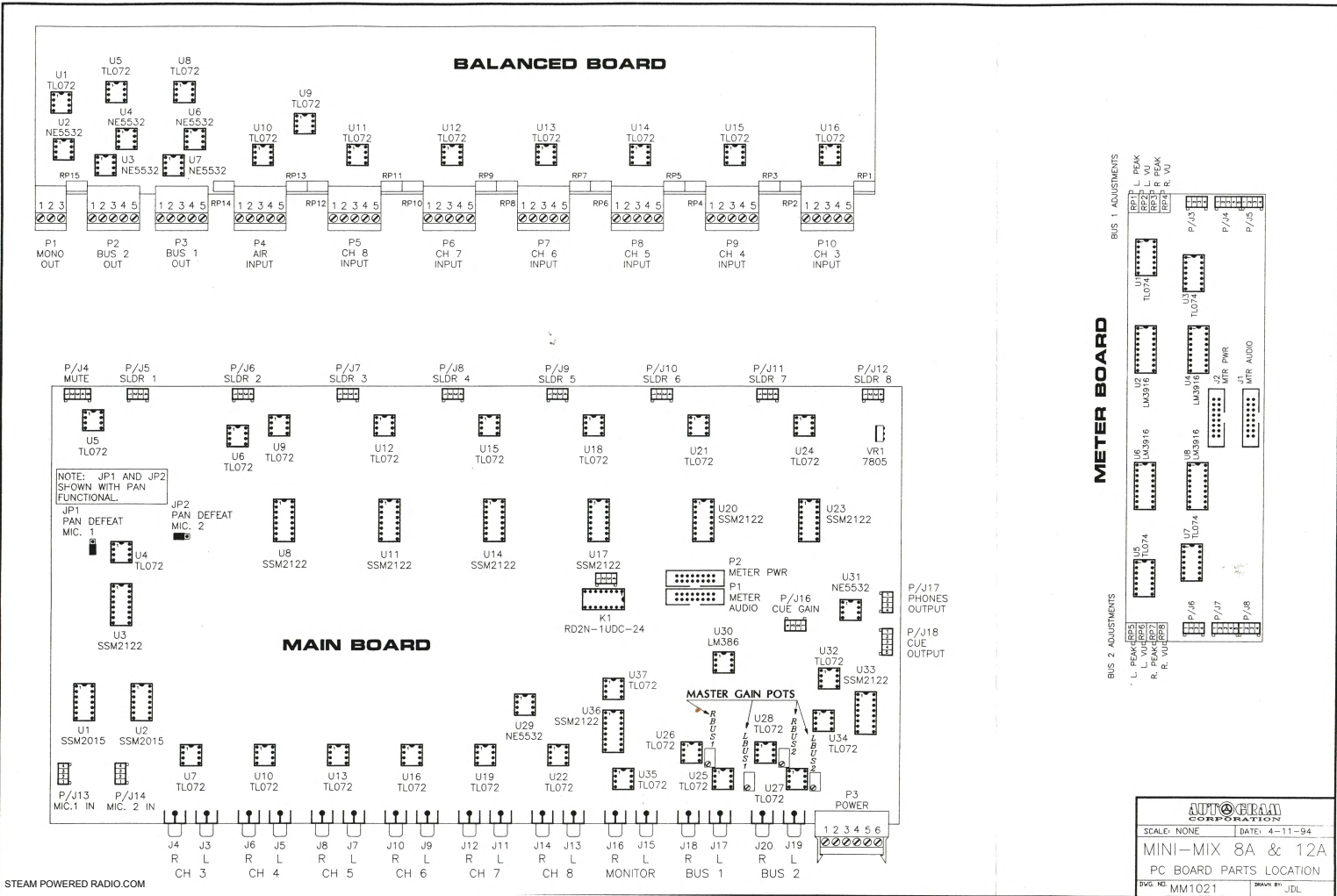

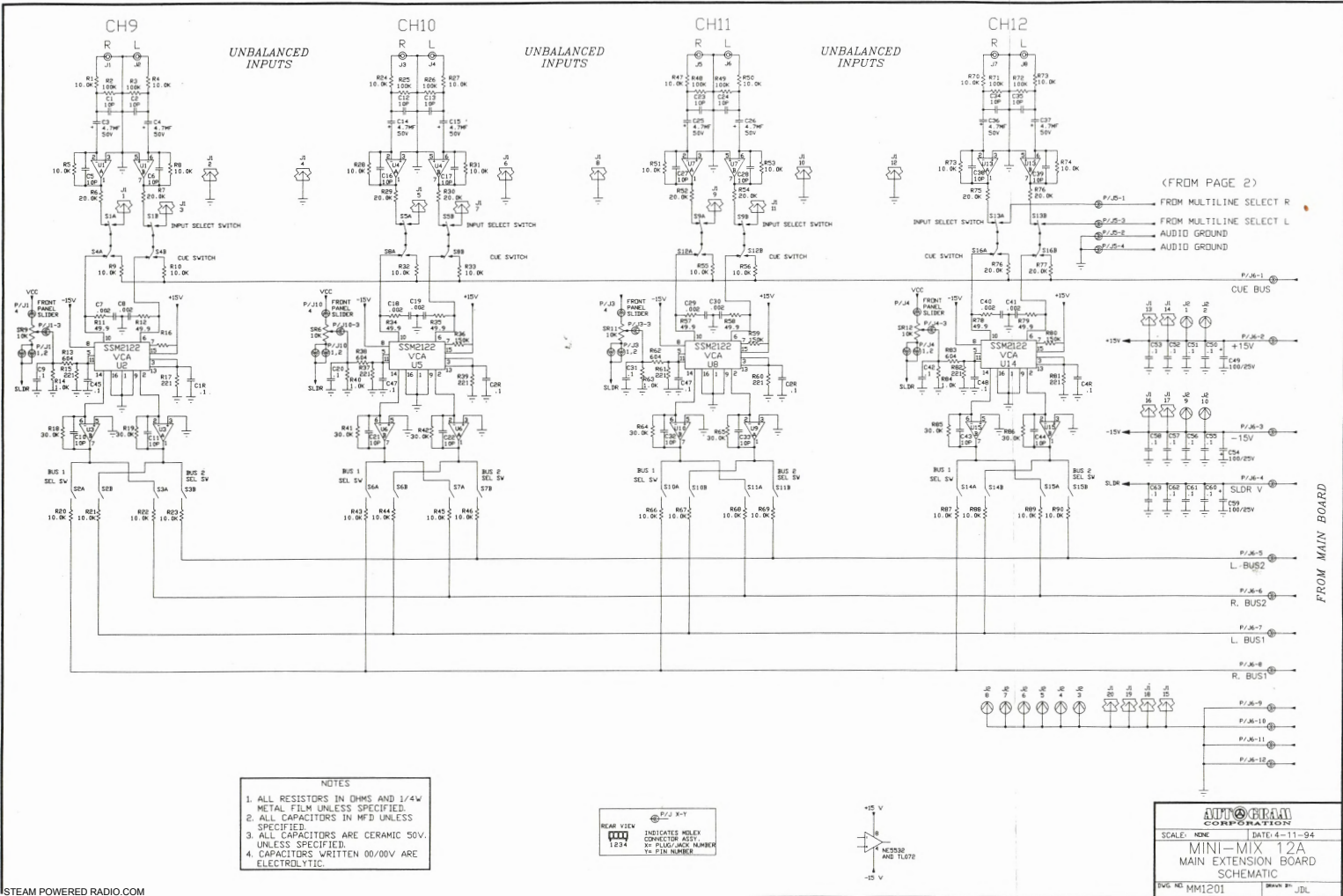

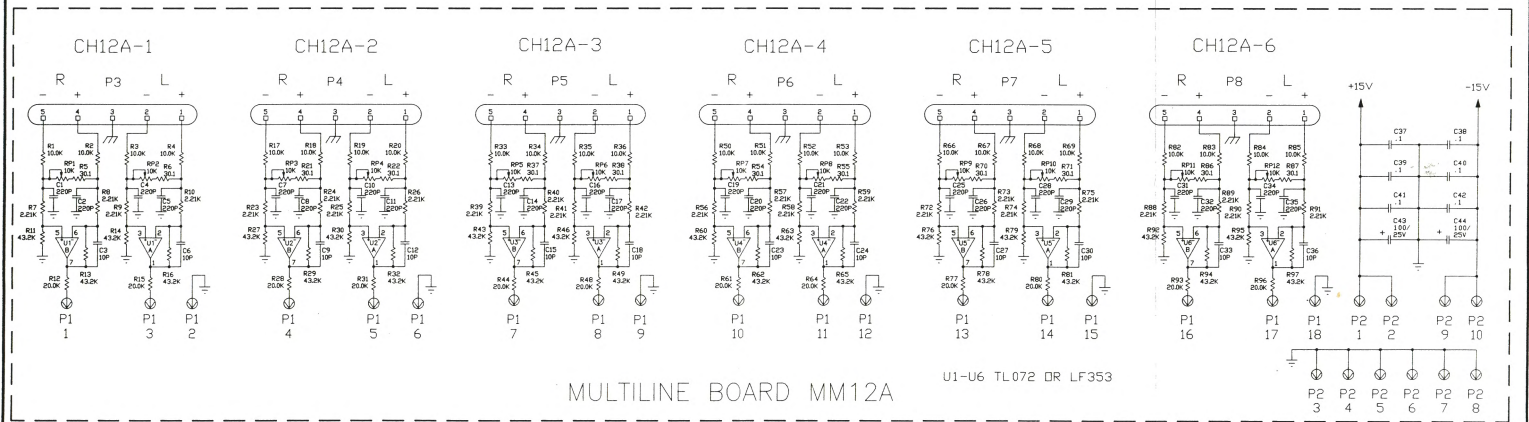
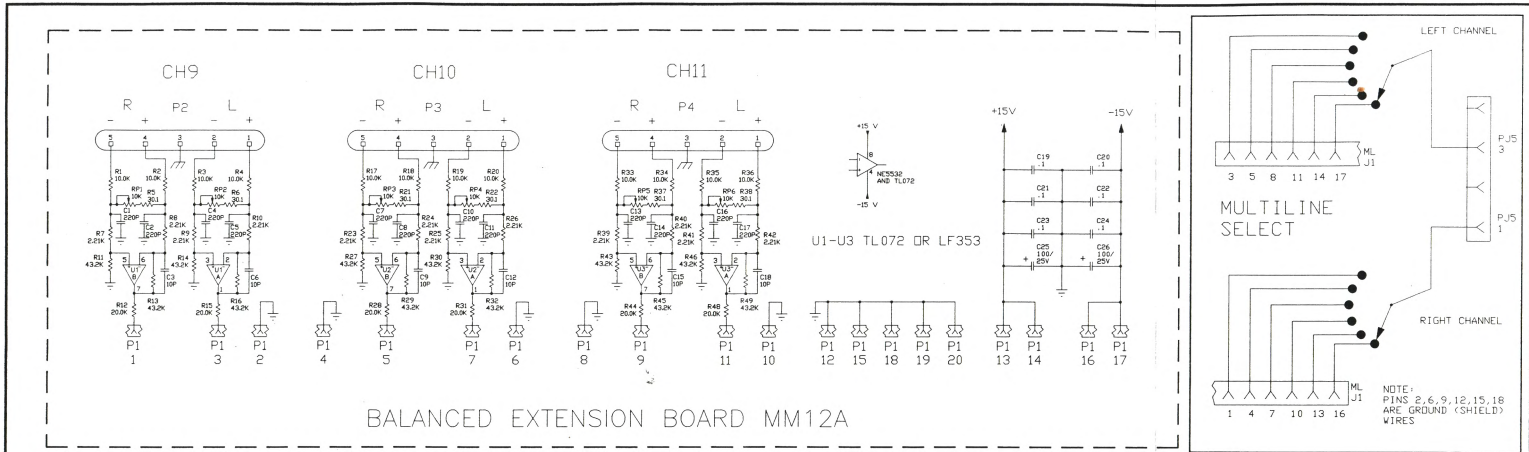

- NOTES
1. ALL RESISTORS IN OHMS AND 1/4W METAL FILM UNLESS SPECIFIED.
 2. ALL CAPACITORS IN MF UNLESS SPECIFIED.
 3. ALL CAPACITORS ARE CERAMIC 50V UNLESS SPECIFIED.
 4. CAPACITORS WRITTEN 0V/50V ARE ELECTROLYTIC.



ADDITIONAL CORPORATION

SCALE: NONE DATE: 4-11-94

MINI-MIX 12A

BALANCED EXTENSION AND MULTILINE BOARDS SCHEMATIC

REV: MM1202

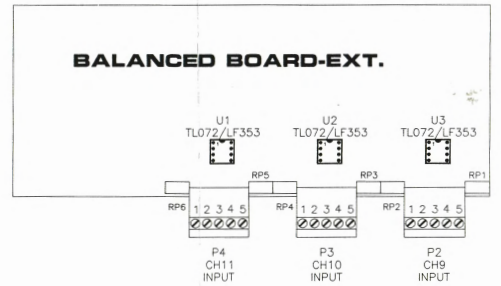
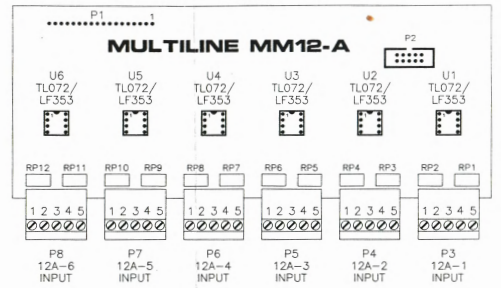
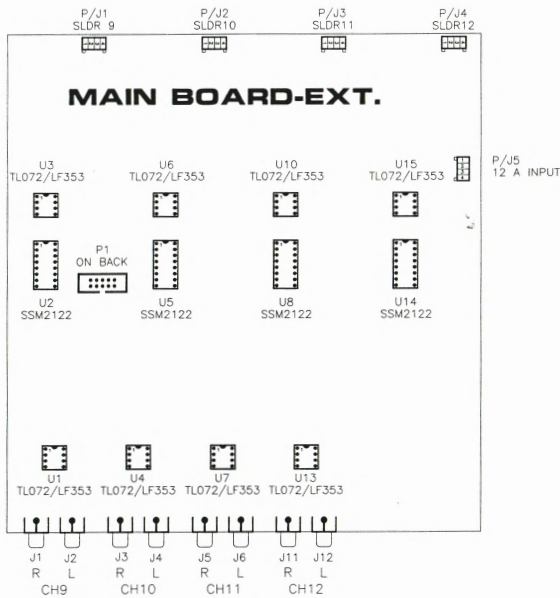



NO POSTAGE
NECESSARY
IF MAILED
IN THE
UNITED STATES

BUSINESS REPLY MAIL

FIRST-CLASS MAIL PERMIT NO. 3626 PLANO, TX

POSTAGE WILL BE PAID BY ADDRESSEE

AUTOGRAM CORPORATION

1500 CAPITAL AVE.
PLANO, TEXAS 75074-9984

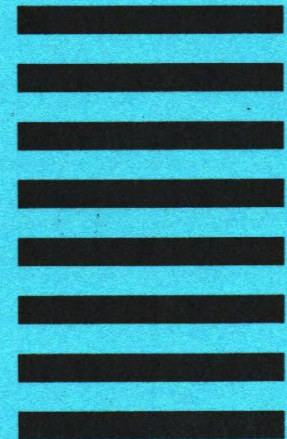

**I WANT TO KNOW MORE ABOUT
AUTOGRAM CONSOLES!**

Please send me literature on the items I have circled:

\$
Mini Mix 8A - 8 Slide Pot
12 Inputs/2 Mic.

Mini Mix 12A - 12 Slide Pot
25 Inputs/2 Mic.

\$\$
Pacemaker Line:
PM618 - 6 Slide Pot- 18 Inputs
PM648 - 6 Slide Pot- 48 Inputs
PM828 - 8 Slide Pot -28 Inputs
PM1032 - 10 Slide Pot - 32 Inputs
PM1644 - 16 Slide Pot- 44 Inputs

AC6 - 6 Rotary Pot - 23 Inputs
AC8 - 8 Rotary Pot - 26 Inputs
IC10 - 10 Rotary Pot - 28 Inputs

\$\$\$
RTV-12 - 12 Slide Pot
24 Inputs

RTV-20 - 20 Slide Pot
34 Inputs



**Plano, Texas
(800) 327-6901**

MY NAME (Please Print) _____

STATION/COMPANY _____

ADDRESS _____

PHONE _____

info@autogramcorp.com www.autogramcorp.com