

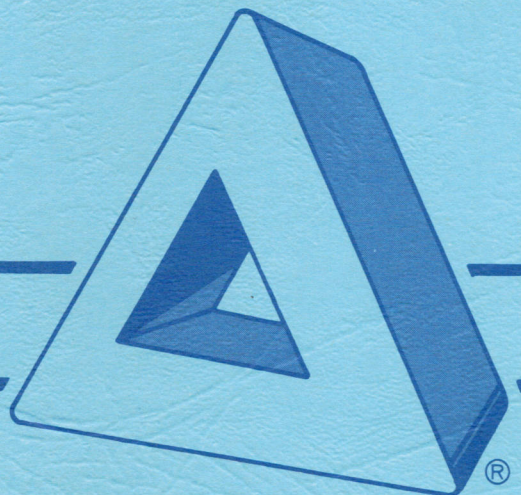
**TECHNICAL MANUAL  
FOR  
MODEL ASE-2  
AM STEREO EXCITER**

---

**DELTA ELECTRONICS**

---

DELTA ELECTRONICS, INC.  
5730 GENERAL WASHINGTON DRIVE  
ALEXANDRIA, VIRGINIA 22312



**TECHNICAL MANUAL  
FOR  
MODEL ASE-2  
AM STEREO EXCITER**

**MODEL ASE-2 AM STEREO EXCITER**

**FCC TYPE ACCEPTANCE NUMBER DK7ASE-2**

**©C-QUAM is a registered trademark of Motorola, Inc.  
Delta C-QUAM equipment is manufactured  
under license from Motorola, Inc.**

**DELTA ELECTRONICS, INC.  
5730 GENERAL WASHINGTON DRIVE  
ALEXANDRIA, VIRGINIA 22312  
U.S.A.**

**Telephone: 703-354-3350  
Toll Free: 1-800-8-DELTA-8  
Facsimile: 703-354-0216  
Telex: 90-1963**

## CERTIFICATE OF WARRANTY

Delta Electronics, Inc. warrants to Purchaser that the product it delivers is free of defects in materials and has high standards of quality and workmanship. This warranty applies to the period of one year from the date of delivery.

Delta Electronics, Inc. will, at its own expense and, after written notice has been received and acknowledged by Delta, repair or replace any product which is defective (according to the usage of the trade) during the above designated warranty period when Delta Electronics, Inc. receives such product at its Alexandria address with shipment costs prepaid by Purchaser.

Delta Electronics, Inc. is not liable for consequential damages.

No other warranty is expressed or implied.

## TABLE OF CONTENTS

<b>1</b>	<b>GENERAL INFORMATION</b> .....	1-1
1.1	Scope .....	1-1
1.2	Equipment Description .....	1-1
1.3	What is C-QUAM .....	1-3
1.3.1	Amplitude Modulation .....	1-4
1.3.2	Phase Modulation .....	1-4
1.3.3	Combining Amplitude and Phase Modulation .....	1-5
1.3.4	Suppressed Carrier Modulation .....	1-5
1.3.5	Generating C-QUAM .....	1-6
<b>2</b>	<b>SPECIFICATIONS</b> .....	2-1
<b>3</b>	<b>THEORY OF OPERATION</b> .....	3-1
3.1	Introduction .....	3-1
3.2	Theory of C-QUAM .....	3-1
3.3	ASE-2 Audio Circuits .....	3-3
3.3.1	Audio Input .....	3-3
3.3.2	Input Balance .....	3-3
3.3.3	High Frequency Equalization .....	3-3
3.3.4	Audio Output Circuit .....	3-4
3.3.5	Low Frequency Equalization .....	3-5
3.3.6	Temperature Compensation .....	3-5
3.3.7	Variable Delay - 1 to 8 Microseconds .....	3-5
3.3.8	Fixed Delay .....	3-6
3.3.9	Q Path Audio Matrix Circuits .....	3-6
3.3.10	Pilot Circuit .....	3-7
3.3.11	Synchronous Transmitter Option - Pilot Circuit .....	3-7
3.4	ASE-2 Radio Frequency Circuits .....	3-8
3.4.1	Quam Modulator .....	3-8
3.4.2	Synchronous Transmitter Option - RF Circuit .....	3-8
3.4.3	Sync Output .....	3-9
3.4.4	Elliptical Filter and Amplifiers .....	3-9
3.4.5	Limiter and TTL Line Driver .....	3-9
3.4.6	High Level Output Option .....	3-10
3.5	ASE-2 Power Supply .....	3-10
<b>4</b>	<b>INSTALLATION</b> .....	4-1
4.1	Introduction .....	4-1
4.2	Rack Mounting .....	4-1
4.3	AC Power Connections .....	4-1
4.4	Left Audio Input and Right Audio Input .....	4-2
4.5	Audio Output .....	4-2
4.6	Synchronous Transmitter Operation (Option) .....	4-3
4.7	SYNC Output .....	4-3
4.8	TTL Output .....	4-3
4.9	High Level Output (Option) .....	4-3

**TABLE OF CONTENTS - CONTINUED**

<b>5</b>	<b>EQUIPMENT PERFORMANCE ADJUSTMENTS</b> .....	<b>5-1</b>
5.1	Introduction .....	5-1
5.2	Stereo Modulation Monitor .....	5-1
5.3	Neutralization and Transmitter Tuning .....	5-1
5.4	Test Setup .....	5-2
5.5	Adjustment of Separation Control .....	5-3
5.6	Delay Adjustment .....	5-3
5.7	High Frequency Equalization Adjustment .....	5-4
5.8	Low Frequency Equalization Adjustment .....	5-5
5.9	Audio Input Balance Adjustment .....	5-5
5.10	Delay Required in I (Audio) Path .....	5-5
5.11	Performance Evaluation .....	5-6
5.12	Pilot Oscillator Select .....	5-6
5.13	Clear Plastic Access Cover .....	5-6
5.14	Occupied Bandwidth and Spurious Output Compliance .....	5-6
5.15	Adjustment of Stereo Audio Processing .....	5-7
5.16	Synchronous Operation .....	5-9
5.17	Pattern Change .....	5-9
<b>6</b>	<b>MAINTENANCE</b> .....	<b>6-1</b>
6.1	Introduction .....	6-1
6.2	Cleaning .....	6-1
6.3	Carrier Oscillator Adjustment .....	6-1
6.4	Pilot Level and Frequency Check .....	6-1
6.5	Repairs .....	6-2
6.6	Alignment Procedure .....	6-2
	6.6.1 Equipment Required .....	6-3
	6.6.2 Electrical Alignment .....	6-3
<b>7</b>	<b>LIST OF MATERIAL</b> .....	<b>7-1</b>
7.1	ASE-2 System Components .....	7-3
7.2	Final Assembly, ASE-2 AM Stereo Exciter .....	7-4
7.3	Exciter Assembly .....	7-5
	<b>APPENDIX A, A VECTOR APPROACH TO C-QUAM</b> .....	<b>A-1</b>

## LIST OF ILLUSTRATIONS

1-1	Illustration of Complete Equipment .....	1-2
1-2A	Amplitude Modulated Waveform .....	1-4
1-2B	Amplitude Modulation Spectrum .....	1-4
1-3A	Phase Modulated Waveform .....	1-5
1-3B	Phase Modulation Spectrum .....	1-5
1-4A	Suppressed Carrier Modulation Waveform .....	1-6
1-4B	Suppressed Carrier Modulation Spectrum .....	1-6
1-5	AM Stereo Transmission System .....	1-6
3-1	ASE-2 Block Diagram .....	3-11
3-2	Audio Input and HF Equalization Section Schematic Diagram .....	3-12
3-3	LF Equalization and Audio Output Section Schematic Diagram .....	3-13
3-4	Delay Section Schematic Diagram .....	3-14
3-5	Matrix and Pilot Section Schematic Diagram .....	3-15
3-6	RF Section Schematic Diagram .....	3-16
3-7	Filter and RF Output Section Schematic Diagram .....	3-17
3-8	Power Supply Section Schematic Diagram .....	3-18
4-1	TTL Interface .....	4-3
4-2	High Level Interface .....	4-4
4-3	$\pi$ Matching Network .....	4-4
5-1	Test Setup .....	5-2
5-2	Exciter Switch Box .....	5-2
5-3	Monitor Switch Box .....	5-2
5-4	Combined Switch Box .....	5-3
5-5	Correct Audio Phasing .....	5-4

**LIST OF ILLUSTRATIONS - CONTINUED**

<b>5-6</b>	<b>Incorrect Audio Phasing .....</b>	<b>5-4</b>
<b>5-7</b>	<b>Single Channel with Distortion .....</b>	<b>5-5</b>
<b>5-8</b>	<b>Single Channel with Distortion and IPM .....</b>	<b>5-6</b>
<b>5-9</b>	<b>Stereo Program Modulation .....</b>	<b>5-7</b>
<b>5-10</b>	<b>Single Channel Limiting .....</b>	<b>5-8</b>
<b>7-1</b>	<b>Component Locations, Top View .....</b>	<b>7-2</b>

**LIST OF TABLES**

<b>1-1</b>	<b>Model ASE-2 Configurations .....</b>	<b>1-3</b>
<b>6-1</b>	<b>Equipment Required .....</b>	<b>6-3</b>
<b>6-2</b>	<b>Filter Stopband .....</b>	<b>6-10</b>
<b>6-3</b>	<b>Filter Passband .....</b>	<b>6-10</b>

**TECHNICAL MANUAL**  
**FOR**  
**MODEL ASE-2**  
**AM STEREO EXCITER**

**SECTION 1**

**GENERAL INFORMATION**

**1.1 SCOPE**

This manual describes the operation, installation and maintenance of the Model ASE-2 AM Stereo Exciter manufactured by Delta Electronics, Inc. Section 1 contains a brief overview of the theory of C-QUAM® AM stereo with a more thorough treatment in Appendix A. Section 2 contains the specifications of the ASE-2; Section 3 provides theory of operation of each circuit; Section 4 provides installation instructions; Section 5 describes the adjustment of the ASE-2, the transmitter and the audio processing; Section 6 provides maintenance information and Section 7 contains lists of materials for all replaceable components.

This manual is intended for use only by personnel familiar with potentially hazardous electrical and electronic circuitry. It does not contain a complete statement of safety precautions. The information presented is accurate up to issue date but Delta can neither assume responsibility for technical application of that information nor for damages or injuries resulting from the use of the subject C-QUAM stereo equipment.

**1.2 EQUIPMENT DESCRIPTION**

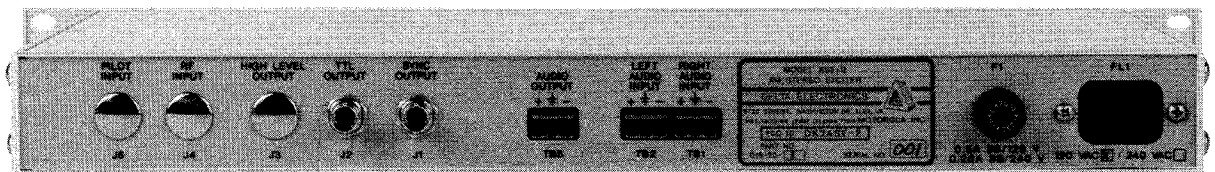
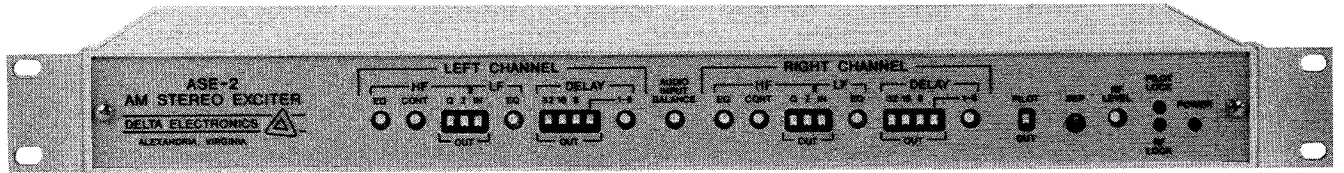
The Model ASE-2 AM Stereo Exciter converts a broadcast transmitter operating in the medium wave band (530 kHz to 1700 kHz) from monophonic to stereo operation using the C-QUAM standard. Figure 1-1 shows front and rear views of the exciter. Balanced audio inputs from the audio processing equipment are connected to the LEFT AUDIO INPUT and the RIGHT AUDIO INPUT connectors. The AUDIO OUTPUT connector provides a balanced audio signal for the transmitter's modulator. This is the main channel audio (left channel plus right channel) which amplitude modulates the carrier inside the transmitter just as in monophonic operation. The front panel SEP control sets the level of this audio for best stereo separation.

The ASE-2 also generates an RF signal to replace the transmitter's crystal oscillator. This RF signal is phase modulated and contains the stereo subchannel (left channel minus right channel)

---

® C-QUAM is a registered trademark of Motorola, Inc.





**Figure 1-1**

**Illustration of Complete Equipment**

information. The RF signal is available in two forms, a TTL level square wave from the TTL OUT connector or an optional, adjustable high level square wave from the HIGH LEVEL OUTPUT connector. The RF output employed is determined by the transmitter's requirements. The ASE-2 has equalization filters and delay circuits which control the properties of the phase modulated RF signal to compensate for transmitter characteristics. When these controls are correctly adjusted, the transmitter produces accurate C-QUAM AM stereo modulation.

The front panel has a removable, clear plastic cover to prevent inadvertent misadjustments of controls. Removal of this plastic cover accesses the setup controls. The Model ASE-2 is specifically designed so that all switches and controls are adjustable from the front panel. Thus, installation testing may be done with the ASE-2 permanently installed in an EIA standard equipment rack. Details of the installation steps and adjustments of the various controls and switches are found in Sections 4 and 5.

The Model ASE-2 has three options which must be specified when ordered. The first option is the internal wiring for line voltage. This wiring is indicated on the rear panel as either 120 VAC or 240 VAC. Special line voltages such as nominal 100/200 VAC at 50 Hz are available upon request. The second option is for high level output. The standard unit provides a TTL level RF output, as required by most newer transmitters. Transmitters with tube type oscillator circuits generally require the high level output option. The third option is for synchronous transmitter operation where a carrier reference signal and a pilot reference signal must be supplied to their respective connectors on the rear panel. Table 1-1 defines the Delta part number for each combination of options.

Table 1-1 Model ASE-2 Configurations		
Description	Delta Part Number for 120/240 VAC Operation	Delta Part Number for 100/200 VAC Operation
Standard unit without options, TTL RF drive	D15-20-1	D15-20-5
Standard unit with High Level Output option	D15-20-2	D15-20-6
Standard unit with Synchronous Transmitter option	D15-20-3	D15-20-7
Standard unit with Synchronous Transmitter option and High Level Output option	D15-20-4	D15-20-8

### 1.3 WHAT IS C-QUAM?

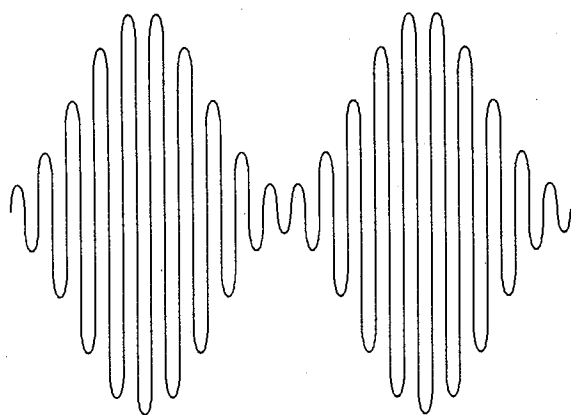
C-QUAM is the Compatible Quadrature Amplitude Modulation method of stereo transmission by which a main channel (left channel plus right channel) signal and a subchannel (left channel minus right channel) signal are transmitted on a single carrier. This is accomplished by using two modulation modes to transmit the main channel and subchannel information. Stereo receivers separate the signals to ultimately produce left and right channel audio while typical monophonic

receivers detect only the main channel content of the C-QUAM signal. The most important feature of C-QUAM is that no compromise is made in monophonic performance in order to transmit stereo. It is truly a compatible stereo transmission system.

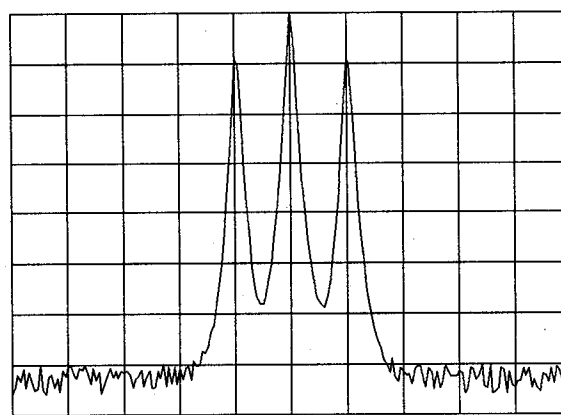
The remainder of this section is a brief overview of how the ASE-2 generates C-QUAM AM stereo.

### 1.3.1 Amplitude Modulation

Amplitude modulation (AM) is the process in which one signal's amplitude is varied by another signal. The signal whose amplitude is changed is called the carrier and the signal controlling the amplitude is called the modulating signal. In a radio station, the carrier is at the station's assigned operating frequency. An oscilloscope display depicts the amplitude variation versus time of the AM signal. This is the familiar radio frequency (RF) envelope display illustrated in Figure 1-2A. For clarity, this illustration shows the modulating signal as a single tone at one tenth the carrier frequency.



**Figure 1-2A**  
*Amplitude Modulated Waveform*

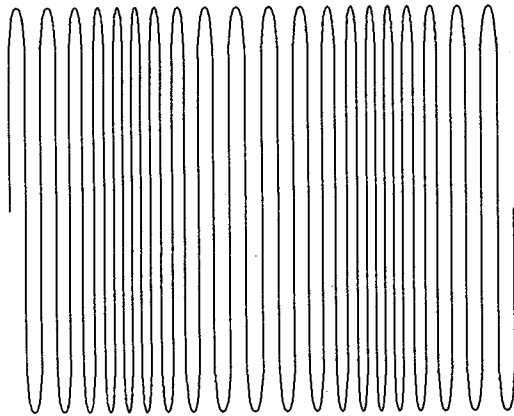


**Figure 1-2B**  
*Amplitude Modulation Spectrum*

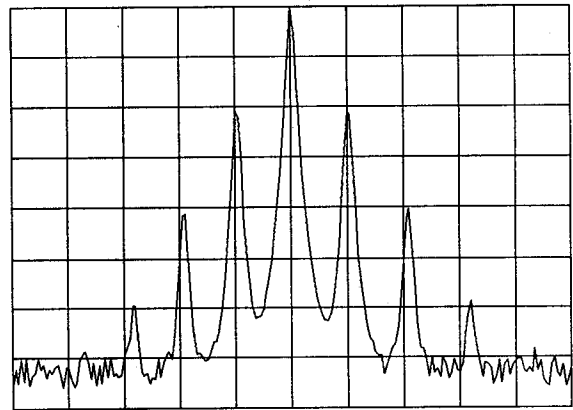
The AM signal can also be described in the frequency domain with an amplitude versus frequency plot. Figure 1-2B illustrates a typical spectrum analyzer display of an AM signal modulated by a single tone. The display reveals a carrier and two sidebands separated from the carrier by the modulating frequency. In AM, as the modulation is increased, the sideband amplitudes increase but the average carrier level remains constant.

### 1.3.2 Phase Modulation

Phase modulation (PM), sometimes called angle modulation, results in very different time and frequency domain plots. PM is generated by varying the phase of the carrier signal, and thus its instantaneous frequency, while the amplitude remains constant. Figure 1-3A illustrates a PM signal as viewed on an oscilloscope. Again for clarity, the modulating signal is a single tone at one tenth the carrier frequency. The spectrum analyzer plot of a single tone modulated PM signal, shown in Figure 1-3B, reveals sidebands spaced at multiples of the modulating frequency from the carrier. Since the amplitude signal is constant, the phasing of the sidebands is such that they add and subtract with the carrier to produce a constant amplitude.



**Figure 1-3A**  
*Phase Modulated Waveform*



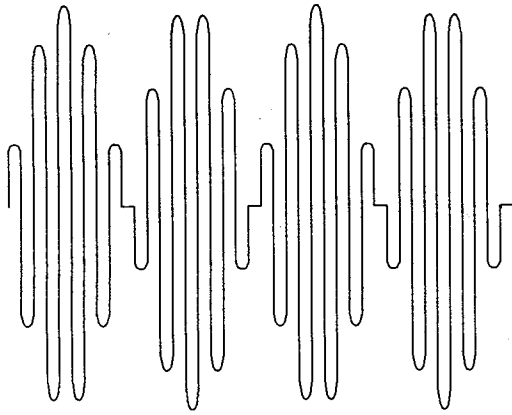
**Figure 1-3B**  
*Phase Modulation Spectrum*

### 1.3.3 Combining Amplitude and Phase Modulation

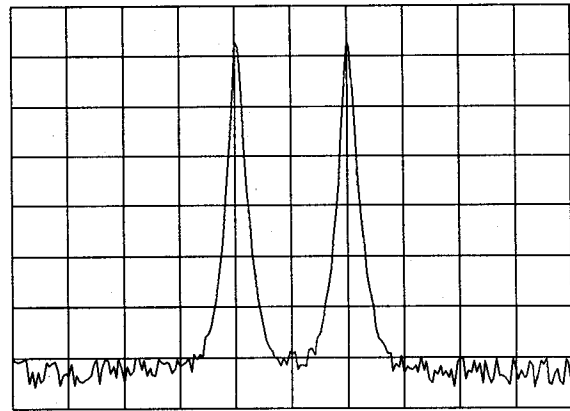
Since the phase of the carrier is not affected by amplitude variations, a phase detector has no output when an AM signal is applied. Similarly, an envelope (amplitude modulation) detector does not respond to the phase variations of a PM signal since all the sidebands add and subtract according to their phasing to produce a constant amplitude RF signal. Thus, a phase modulated carrier can also be amplitude modulated producing a signal that carries two channels of information easily separated at the receiver. Most important is the fact that neither modulation mode affects the output of the other mode's detector. This effect allows C-QUAM to be compatible with all AM receivers. C-QUAM transmits the main channel (L+R or monophonic) information with AM while the subchannel (L-R) information is contained in the PM signal. All existing envelope detector type radios now in use detect only the L+R AM signal, thus producing a clear and undistorted monophonic audio that is unaffected by the L-R subchannel information sent on the same carrier. Stereo decoders detect the L+R and L-R separately and dematrix them to produce left channel and right channel audio.

### 1.3.4 Suppressed Carrier Modulation

Another form of modulation important in the generation of C-QUAM is suppressed carrier modulation. Suppressed carrier modulation is the same as amplitude modulation with the carrier frequency component removed. Figure 1-4A shows the time domain plot of suppressed carrier modulation using a single tone. For clarity, the modulating frequency is one tenth the carrier frequency. This is the same modulating frequency as in Figure 1-2A but notice that twice as many "humps" exist in the envelope. Figure 1-4B is a frequency domain plot of single tone suppressed carrier modulation. Notice that only the two sidebands exist and that they are spaced at the modulating frequency away from the missing carrier.



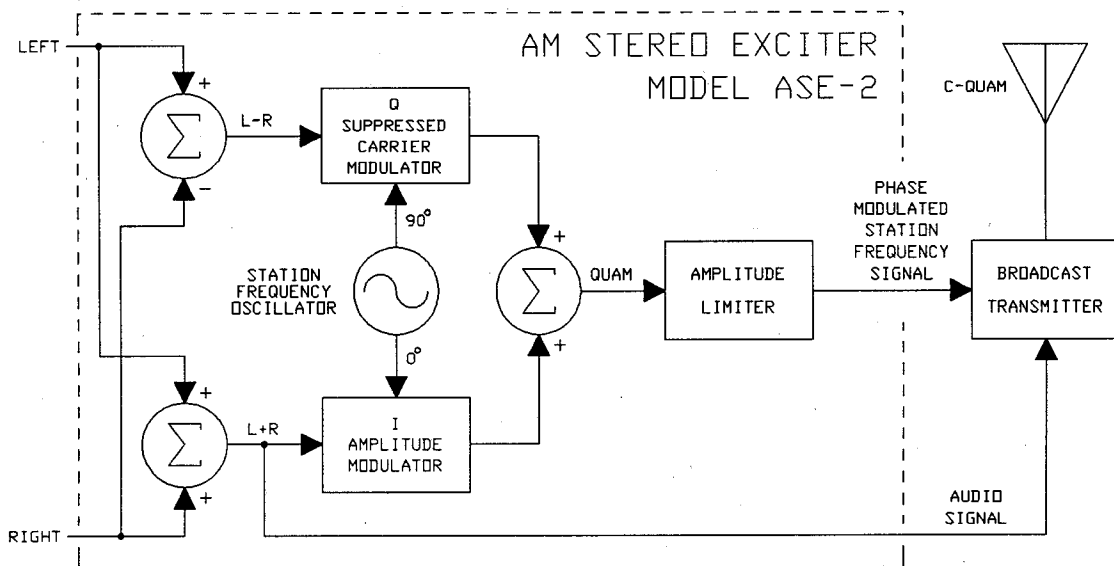
**Figure 1-4A**  
*Suppressed Carrier Modulation Waveform*



**Figure 1-4B**  
*Suppressed Carrier Modulation Spectrum*

### 1.3.5 Generating C-QUAM

Several methods exist to broadcast in stereo using the combination of amplitude modulation and phase modulation. The C-QUAM method, originally developed by Motorola Inc., has become the dominant method and has been adopted by several countries as their national standard. Figure 1-5 is a simplified block diagram of an AM stereo transmission system. The C-QUAM exciter produces an RF and an audio signal for the existing broadcast transmitter. The audio signal is simply the sum of the left and right channel audio scaled to produce the correct amount of amplitude modulation in the broadcast transmitter.



**Figure 1-5**  
*AM Stereo Transmission System*

The phase modulated carrier frequency RF signal is produced as follows. The main channel audio (L+R) amplitude modulates a carrier frequency signal in the I (in phase) modulator. The subchannel audio (L-R) suppressed carrier modulates a carrier at the same frequency as the AM modulator but with a 90 degree phase shift in the Q (quadrature) modulator. This is called quadrature modulation because the 90 degree carrier is said to be "in quadrature with" the AM carrier. The output of these two modulators is summed to produce a signal called the QUadrature Amplitude Modulation (QUAM) signal. This signal contains all of the stereo information and would be an excellent way to transmit stereo except that it is not compatible with envelope detectors because the quadrature modulation introduces envelope distortion. Instead, the QUAM signal is stripped of its amplitude variations by a limiter. The resulting phase modulated signal is the RF drive to the broadcast transmitter.

For a more detailed theoretical discussion of C-QUAM AM stereo, see Appendix A of this technical manual.

**SECTION 2**  
**SPECIFICATIONS**

- Stereo Separation** . . . . . Closed loop performance using an external, high performance sample transmitter:
- 50% Single Channel - 40 dB minimum, 50 Hz to 10 kHz  
(typically >45 dB at 1 kHz)
- 75% Single Channel - 35 dB minimum, 50 Hz to 10 kHz
- Frequency Response** . . . . .  $\pm 0.5$  dB from 50 Hz to 10 kHz at any modulation
- Harmonic Distortion** . . . . . 0.2% maximum THD+N at 95% monaural modulation (L=R)  
0.5% maximum THD+N at 100% subchannel (L=-R)
- Residual Hum and Noise** . . . -55 dB maximum referenced to 100% modulation level at any modulation monitor output (L, R, L+R or L-R)
- Carrier Frequency** . . . . . Crystal controlled at customer specified operating frequency within the 530 kHz to 1700 kHz band.
- Carrier Frequency versus Temperature** . . . . .  $\pm 10$  Hz maximum from 0°C to 50°C
- RF Outputs** . . . . . TTL OUTPUT: BNC connector with standard TTL level square wave drive for 50 or 75 ohm load
- SYNC OUTPUT: BNC connector with an unmodulated carrier frequency square wave at 0.1 Vp-p into 50 ohms
- HIGH LEVEL OUTPUT (optional): BNC connector with adjustable high level square wave output of up to 35 Vp-p into 50 or 75 ohms
- Pilot Level** . . . . . 5.0% nominal
- Pilot Frequency** . . . . . 25.00 Hz  $\pm 0.02$  Hz
- Audio Input** . . . . . Left and Right channel balanced 600 ohms at nominal +10 dBm
- Audio Output** . . . . . Balanced 600 ohms with front panel adjustable level to +16 dBm
- Equalization Filters** . . . . . Front panel adjustable high pass and low pass filters provide for amplitude and phase equalization between the transmitter's RF and audio circuits
- Delay Filters** . . . . . Front panel adjustable all pass filters equalize the group delay between the transmitter's RF and audio circuits - Delay range from 0 to 64  $\mu$ S

**Synchronous Inputs** . . . . . With the synchronous transmitter option installed, the external RF INPUT and PILOT INPUT signals must have the following characteristics:

RF Reference: 0.8 to 8 Vp-p into 50 ohms nominal

Pilot Reference: 25 Hz  $\pm$ 0.05 Hz at 0.1 to 20 Vp-p into 50K ohm

**Operating Temperature** . . . . 0 to +50° C

**Power** . . . . . 100/120/200/240 VAC  $\pm$ 10%, 47/63 Hz - Maximum power consumption is 48 watts

**Dimensions** . . . . . 19" wide (483 mm) x 1.75" high (45 mm) x 12" deep (235 mm)

**Weight** . . . . . 8 lbs (3.6 kg)

**Accessories** . . . . . Sample Transmitter - for closed loop testing with a stereo modulation monitor - Delta part number D15-21

Stereo Switch Box - facilitates test and alignment as described in Section 5.4 - Delta part number D61-107

High Purity Filter - used with HIGH LEVEL OUTPUT option for sine wave output at 0 to 5 Vrms into 50 Ohms with all carrier harmonics below -60 dBc - Delta part number D60-12



## SECTION 3

### THEORY OF OPERATION

#### 3.1 INTRODUCTION

The Delta Electronics Model ASE-2 AM Stereo Exciter is designed for conversion of an amplitude modulated transmitter operating in the medium wave band (530 - 1700 kHz) from monophonic to stereo operation. With balanced left and right channel audio inputs, the ASE-2 provides a balanced audio output to the audio input of the transmitter's modulator and provides a phase modulated carrier frequency signal to replace the transmitter's crystal oscillator. The audio feed to the transmitter is the stereo main channel information, the algebraic sum of the left and right channels (L+R). The stereo subchannel information, the difference between the left and right channels (L-R), is contained in the phase modulated carrier according to the C-QUAM (Compatible QUadrature Amplitude Modulation) standard. The ASE-2 contains all the delay and equalization circuits necessary to compensate for time delay differences between the transmitter's audio and RF chains and to compensate for the frequency response of the transmitter's modulator.

#### 3.2 THEORY OF C-QUAM

The following is a brief description of C-QUAM AM Stereo necessary for understanding the operation of the Model ASE-2. Section 1.2 is a simple explanation of C-QUAM. For a more detailed theoretical description, see Appendix A.

Perhaps the best method for AM stereo transmission would be quadrature amplitude modulation (QUAM) where the stereo main channel audio (L+R) AM modulates a RF carrier and the stereo subchannel audio (L-R) modulates a quadrature suppressed carrier (double sideband suppressed carrier modulation at 90 degrees phase referenced to the RF carrier). This scheme would require no additional spectrum and the stereo audio would be recovered by synchronous detectors. Unfortunately, quadrature amplitude modulation is not compatible with envelope detectors in existing monophonic radios because the quadrature modulation components produce distortion in the envelope. Also, synchronous detectors lose phase lock in weak signal conditions and all reception is lost.

One solution to this problem which has found widespread acceptance is called Compatible Quadrature Amplitude Modulation or C-QUAM for short. In the C-QUAM system, the carrier is amplitude modulated with main channel audio (L+R) in the transmitter's modulator the same as in monophonic operation thus guaranteeing compatibility with envelope detectors. The subchannel information is contained in a phase modulated carrier substituted for the transmitter's crystal oscillator. This phase modulated carrier has the phase of quadrature amplitude modulation (QUAM). That is, the phase modulated carrier is derived from a QUAM modulator fed through an RF limiter. Figure 1-5 is a simplified block diagram for this method of generating C-QUAM.

A 25 Hz 5% pilot signal is added to the subchannel audio to turn on the receiver's stereo decoder. The stereo decoder adjusts the amplitude of the envelope to produce QUAM which is synchronously detected recovering the main and subchannel audio. If the receiver is in a weak signal

area, the 25 Hz pilot signal will not turn on the stereo decoder and the receiver will revert to envelope detection.

Figure 3-1 is a block diagram of the Model ASE-2 AM stereo exciter. Each section of this diagram has dashed lines to indicate areas covered by individual schematic diagrams. The ASE-2 circuits may be divided into four functional types: audio circuits, RF circuits, the pilot circuit and the synchronous transmitter option circuits.

The left channel and right channel balanced audio inputs are converted to unbalanced signals and are fed to a channel balancing circuit which allows for correction of small level differences between the two inputs. The left channel and right channel audio signal connect to high frequency equalization circuits. The HF EQ switches place the high frequency equalization circuits in the I audio path or the Q audio path (or neither) as required to compensate for transmitter characteristics. The I path is the audio path to the transmitter's modulator and the Q path is the audio path to the ASE-2's QUAM modulator. Figure 3-1 shows the high frequency equalization circuits placed in the Q path which is typical for most transmitters.

The I path audio proceeds to the  $(L+R)_I$  matrix which sums the left and right channel audio yielding a main channel signal. This signal is converted to a balanced output and is fed to the transmitter modulator through AUDIO OUTPUT connector, TB3. The level of this signal is set by the SEP control for the correct amount of amplitude modulation for minimum stereo separation.

The Q path audio proceeds to low frequency equalization circuits which are switched in or out of the Q path by the LF EQ switches. Figure 3-1 shows the low frequency equalization circuits placed in the Q path. A series of delay circuits follows the low frequency equalization circuit in the Q path. Delay switches allow from one to sixty-four microsecond delay or no delay in the Q path. The low frequency equalization and delay circuits are adjusted as required to compensate for transmitter characteristics.

The left and right channel audio of the Q path is matrixed to produce signals for the in-phase and quadrature modulators. The  $(L+R)_Q$  matrix produces main channel audio with a DC offset  $(1+L+R)$  for amplitude modulation. This signal is clipped at -95% so that the in-phase modulator always produces some RF signal and, therefore, the transmitter will never lose RF drive. The  $(L-R)_Q$  matrix produces subchannel audio for the quadrature modulator. If the PILOT switch is on, a 25 Hz pilot signal at 5% modulation is added to the subchannel signal.

The carrier frequency is controlled by a crystal oscillator operating at four times the carrier frequency. The signal from this oscillator is divided by four producing two carrier frequency signals in quadrature (90 degrees phase difference). The signal labeled  $0^\circ$  is the RF drive for the in-phase modulator and the signal labelled  $90^\circ$  is the RF drive for the quadrature modulator. The output of these two modulators is summed by a hybrid combiner producing a QUAM signal. This signal is amplified and fed to an elliptical lowpass filter to remove carrier frequency harmonics that would interfere with proper operation of the limiter circuit. After further amplification, the filtered QUAM signal is converted to a carrier frequency square wave by the limiter circuit. This square wave carries the phase modulation of the QUAM signal. The TTL line driver circuit and the optional high level output circuit provide the phase modulated square wave signal in a form suitable for connection to the RF circuits of a transmitter through 50 or 75 ohm coaxial cable.

The 25 Hz pilot signal is derived from a 32.768 kHz watch crystal oscillator. Digital division of this signal by 1311 yields a 25 Hz square wave. The harmonics of the square wave are removed

by a bandpass filter and if the PILOT switch is on, the resulting 25 Hz sine wave is added to the subchannel in the (L-R)<sub>Q</sub> matrix.

For synchronous operation, where the station operates more than one transmitter on the same frequency, two optional circuits are added. This allows the station to synchronize both the carrier and pilot frequencies. A carrier frequency reference signal is connected to the RF INPUT connector, J4. One part of the synchronous transmitter option phase locks the four-times-carrier frequency crystal oscillator to the carrier reference signal.

The second part of the synchronous transmitter option provides a pilot frequency square wave to the 25 Hz bandpass filter. This signal is phase locked to a pilot reference signal connected to the PILOT INPUT connector, J5. The 32.768 kHz oscillator and the 1311 divider are disabled for this option.

### **3.3 ASE-2 AUDIO CIRCUITS**

Refer to the functional block diagram of Figure 3-1 and the schematic diagrams of Figures 3-2 through 3-5 in the following discussions.

#### **3.3.1 Audio Input (reference Figure 3-2)**

Since the left channel audio input and right channel audio input circuits are identical, only the right channel circuit is described. Right channel balanced audio at a nominal +10 dBm (600 ohms) level is connected to TB1. Resistors R6 and R7 provide a 600 ohm termination but these resistors may be removed for a higher impedance input if necessary. A two section L-C filter composed of L3, L4, L7, L8, C5, C6, C9 and C10 remove any residual radio frequency energy from the audio inputs. Resistors R20 and R21 terminate this filter. The balanced audio is AC coupled through C17 and C18 to operational amplifier followers, U27B and U27A. Operational amplifier U27C converts the balanced audio input to unbalanced audio with high common mode rejection. This stage provides a slight gain increase to compensate for the gain loss of the input balance circuit.

#### **3.3.2 Input Balance (reference Figure 3-2)**

The unbalanced output from the left channel and right channel audio input stages, U36C and U27C respectively, are connected through R237 and R229 to operational amplifier followers U36D and U27D and the balancing circuit of R241. Resistors R237, R240 and the top half of the front panel AUDIO INPUT BALANCE potentiometer R241 form a voltage divider for the left channel unbalanced audio. As the AUDIO INPUT BALANCE potentiometer is rotated clockwise, the left channel audio level is reduced. Similarly, R229, R232 and the bottom half of the AUDIO INPUT BALANCE potentiometer R241 form a voltage divider for the right channel audio. As the AUDIO INPUT BALANCE potentiometer is rotated clockwise, the right channel audio level is increased. With the AUDIO INPUT BALANCE potentiometer set to the center position, the potentiometer's pointer is vertical and the left and right channels are balanced. The AUDIO INPUT BALANCE control corrects channel imbalances up to 1 dB.

#### **3.3.3 High Frequency Equalization (reference Figure 3-2)**

Since the left channel and right channel high frequency equalization circuits are identical, only the right channel circuit will be described. The circuit of U37 and U38 is a two pole, low pass filter with the corner frequency controlled by R272, the front panel RIGHT CHANNEL/HF/EQ control.

R272 adjusts the DC current into U37A and U37B controlling their transconductance and, thereby, the corner frequency of the filter. As R272 is rotated clockwise, the corner frequency is reduced from above 50 kHz to a minimum of 7 kHz providing increased equalization to compensate for transmitter characteristics. The front panel RIGHT CHANNEL/HF/CONT control, R273, adjusts the Q (contour) of the low pass filter. With R273 fully clockwise, the filter response peaks at about +1 dB just below the filter corner. With R273 in the center position, the filter exhibits a Butterworth (maximally flat) response. With R273 fully counterclockwise, filter Q is reduced producing a gentle rolloff. Filter gain is factory set by R259.

Insertion of the high frequency equalization circuit is controlled by front panel switches S4A and S4B, labelled RIGHT CHANNEL/HF/Q and RIGHT CHANNEL/HF/I respectively. With both S4A and S4B in the down position, the high frequency equalization circuit is bypassed. When S4A is up, the high frequency equalization circuit is inserted in the Q path, the audio path to the RF modulators U19 and U20. This is the usual application of high frequency equalization to compensate the RF phase modulation for the transmitter's modulator response. On rare occasions a transmitter will be encountered which requires high frequency equalization in the I path, the audio going to the transmitter's modulator. This is accomplished by setting S4B to the up position selecting RIGHT CHANNEL/HF/I. Both S4A and S4B should never be switched up although no harm will occur.

### 3.3.4 Audio Output Circuit (reference Figure 3-3)

The I path audio consisting of the left channel audio from S1B and the right channel audio from S4B of the high frequency equalization circuits are summed in the L+R Matrix circuit of U43A. The output of this circuit is the inverted sum  $-(L+R)$ . This inversion is corrected in the output driver circuit. The audio output level is set by the ten turn, front panel SEP control, R326. This control adjusts the audio level to the transmitter's modulator for correct envelope modulation for maximum stereo separation. Best separation occurs at one position of this control and further rotation degrades performance. Note that the SEP control has nothing to do with overall modulation level. If the transmitter is over or under modulating, the audio processor level should be adjusted to correct modulation level.

The audio from R326 is buffered by U43B for two output driver stages of U1 and Q4 through Q7. The driver stages are nearly identical except that U1B is inverting to correct the inversion of U43A resulting in a positive polarity output at TB3 pin 1. U1A is non-inverting and produces a negative polarity output at TB3 pin 3. Since the remainder of each circuit is identical, only the circuit of U1B will be described.

The circuit of U1B has a gain of 1.5 to offset the loss in the push-pull driver circuit of Q6 and Q7. As the signal from U1B rises above ground potential, the base voltage of Q6 rises and Q6 provides more current to the load. As the output of U1B drops below ground potential, the base voltage of Q7 drops and Q7 sinks more current from the load. To reduce cross over distortion to negligible levels, the quiescent bias point of Q6 and Q7 is set by the voltage drop across the light emitting diode, CR12. The DC component of the output is controlled by the inverting integrator of U1C. This circuit has a very low frequency corner so that only the DC component of the output is fed back to U1B. This negative feedback reduces the DC output level to less than 10 mV.

The two drivers have identical audio gain so the output from TB3 is balanced. The output includes resistors R331 and R332 and jumpers W12 and W13. The jumpers are normally installed so that R331 and R332 are in the circuit for a nominal 600 ohm balanced output. Some transmitters require a 600 ohm source for proper operation of input cutback circuits. W12 and W13 may be

placed in the 2-3 position for a low impedance output suitable for driving reactive loads. This may be desirable for some older transmitters with transformer inputs. W12 and W13 are located near the rear panel as shown in Figure 7-1.

Jumpers W6 and W7 are shown connected in their normal position with no delay circuits wired into the I path, the audio to the transmitter's modulators. On rare occasions a transmitter will be encountered which requires delay in the I path. Then these jumpers will be removed and the delay circuits will be wired into the I path as described in Section 5.10.

### **3.3.5 Low Frequency Equalization (reference Figure 3-3)**

Since the right channel and left channel low frequency equalization circuits are identical, only the right channel circuit will be described. The low frequency equalization circuit of U28 is a two pole, high pass filter useful in compensating the RF phase modulation for the low frequency rolloff of the transmitter's modulator. The front panel RIGHT/LF/EQ control, R301, adjusts the DC current into transconductance amplifiers U28A and U28B setting their transconductance and, thereby, the filter corner. Adjusting the RIGHT CHANNEL/LF/EQ control clockwise increases the filter corner frequency from 1.5 to 30 Hz increasing equalization. Filter gain is factory adjusted by R246. The low frequency equalization circuit is switched into operation by front panel switch S4C, the RIGHT CHANNEL/LF/IN switch.

### **3.3.6 Temperature Compensation (reference Figure 3-2)**

The transconductance of each of the transconductance amplifiers in the high frequency equalization and low frequency equalization circuits is controlled by DC current and by absolute temperature. Although the operating temperature range of the Model ASE-2 has only a small fractional change when measured in absolute temperature, a temperature compensation circuit is included to reduce transconductance change with temperature. Reference diode CR17 provides a constant 2.49 VDC independent of temperature. The output voltage of diode CR32 varies directly with absolute temperature. The circuit of U31A amplifies the voltage difference between the temperature diode, CR32, and the voltage from CR17. The gain of U31B produces the required slope of 78.3 mV/°C with a nominal 10 VDC at 27°C. As the ambient temperature increases, the output voltage from U31A increases raising the control currents to the transconductance amplifiers and compensating for the thermal reduction in transconductance.

### **3.3.7 Variable Delay - 1 to 8 Microseconds (reference Figure 3-4)**

Since the right channel and left channel delay circuits are identical, only the right channel circuit will be described. With switch S5D in the down or OFF position, the one to eight microsecond delay circuit is out of the circuit and no delay occurs. When switch S5D, the RIGHT CHANNEL/DELAY/1-8 switch, is in the up position, the one to eight microsecond delay circuit of U39D is inserted into the Q path, the audio going to the RF modulators. This all-pass circuit provides constant gain versus frequency with nearly constant delay to beyond 10 kHz. The RIGHT CHANNEL/DELAY/1-8 control, R302, sets the delay between one and eight microseconds. This control is used for fine adjustments in delay.

Jumpers W9 and W11 are shown connected in their normal position with the delay circuits wired into the Q path, the audio to the RF modulators. On rare occasions a transmitter will be encountered which requires the delay circuits in the I path, the audio going to the transmitter's modulator. Then these jumpers are removed and wired as described in Section 5.10.

### 3.3.8 Fixed Delay (reference Figure 3-4)

Since the right channel and left channel delay circuits are identical, only the right channel delay circuits will be described. The RIGHT CHANNEL/DELAY/8 switch, S5C, inserts the eight microsecond fixed delay circuit of U39C into the Q audio path. This circuit is similar to the one to eight microsecond delay circuit described above with the delay fixed at eight microseconds.

The simple circuit of U39C used to produce an eight microsecond delay cannot maintain sufficiently constant delay versus frequency beyond eight microseconds delay. The more complex circuit of U39A, U39B and U30D provides the necessary performance. The circuit of U39B has a Bessel (maximally flat in phase) bandpass response. The summation of this filter output with the original signal produces a more high performance all-pass circuit with an inverted output. The unity gain inverter of U30D corrects the inverted output of U39A. The RIGHT CHANNEL/DELAY/16 switch, S5B, inserts the sixteen microsecond delay circuit into the Q audio path.

For a constant thirty-two microsecond delay, a still more complex circuit is required. The circuit of U30C and U30A has the same form and function as the circuit of U39B and U39A in the sixteen microsecond delay circuit. The circuit of U30B is an inverting version of the circuit of U39C. The combination of these two circuits with suitably adjusted circuit values produces an all-pass filter with a highly constant thirty-two microsecond delay. The circuit is inserted into the Q audio path by the RIGHT CHANNEL/DELAY/32 switch, S5A.

### 3.3.9 Q Path Audio Matrix Circuits (reference Figure 3-5)

The left and right channel audio signals from the delay circuits are fed through DC blocking capacitors C54 and C55 and are buffered by operational amplifier followers U22D and U22A. The outputs of these buffers feed two matrix circuits, the L+R matrix of U22C and the L-R matrix of U22B. The L+R matrix null control, R124, is factory adjusted so that the L+R matrix has no output when  $L = -R$ . In addition, a DC component from reference diode CR17 through R120 and R121 is added into the L+R audio at U22C summing point, pin 9. The output of the L+R matrix at U22C pin 8 is an inverted audio at nominally +10 dBm (600 ohm) offset by a negative DC voltage equivalent to 100% modulation, nominally 3.46 VDC. At  $L+R=-100%$ , the positive peak voltage at U22C just reaches zero volts.

The gain of inverting stage U23B is set to provide a negative voltage (about -0.9 VDC) such that CR22 acting through R129 soft clips the  $-(1+L+R)$  signal from U22C at -95%. This is necessary to guarantee that there will always be some RF signal from modulator U19 and, therefore, always an RF drive to the transmitter. Diode CR18 is included in the feedback circuit of U23B to compensate for the diode voltage drop and temperature variation of CR22. Operational amplifier follower U23D buffers the clipped  $-(1+L+R)$  audio for inverter U23C. Offset trimmer R126 is factory adjusted to remove accumulated DC input offset voltages of the operational amplifiers in this circuit. Thus, the output at U23C pin 8 is a  $+(1+L+R)$  signal for the in-phase modulator, U19.

The inverting L-R matrix circuit of U22B produces  $-(L-R)$  at pin 7. Null trimmer R138 is factory set to produce no output from the L-R matrix with  $L=R$  input. Inverting operational amplifier stage U23A sums and inverts the  $-(L-R)$  signal from U22B, the 5% pilot signal from the front panel PILOT switch S6A, and an offset trimmer R131. Offset trimmer R131 is factory set to eliminate accumulated operational amplifier input offset voltages at the output of U23A. Thus, the output at U23A pin 1 is a  $+(L-R)$  signal for the quadrature modulator, U20.

### 3.3.10 Pilot Circuit (reference Figure 3-5)

The circuit of inverter U9A and crystal Y2 is a gate oscillator operating at 32,768 Hz. The output of U9A is buffered by U9B, U9C and U9F providing a clock signal for counter U10. When the binary output of U10 reaches a count of 1311, the output of U11A at pin 1 goes high activating the pulse stretching circuit of U9D and U9E. This pulse stretching circuit guarantees that the pulse produced from U9E will be long enough to reset counter U10 to zero. Thus, the count process repeats every 1311 clock pulses. The output of this circuit is pin 14 of U10, the +512 output, which is a 24.99 Hz square wave with 39% duty cycle.

U12 and associated components form a 25 Hz biquad bandpass circuit with a Q of 10. The filter is tuned by R92 so that the output sine wave is 180 degrees out of phase with the input square wave. The output is nominally 2 Vrms and is fed to the summing point of U23A through the front panel PILOT switch, S6A.

### 3.3.11 Synchronous Transmitter Option - Pilot Circuit (reference Figure 3-5)

When the synchronous transmitter option is installed, U9 through U11 are removed and the 25 Hz square wave for the biquad filter of U12 is derived from counter U42. An external 25 Hz pilot signal is fed to the rear panel PILOT INPUT connector J5. This signal can be a sine wave or a square wave of almost any amplitude and duty cycle. The input circuit of C100, R56, CR28 and CR29 limits the waveform to  $\pm 0.6$  volt AC only. U40A amplifies this signal by ten. C92 and C93 eliminate higher frequency components. The signal is further amplified by U40B producing a  $\pm 14$  volt square wave. This square wave is level shifted to a CMOS signal by resistor network R311, R314 and R315. This CMOS signal is the reference signal for the phase comparator of the phase lock loop U32.

The voltage controlled oscillator (VCO) of U32 operates at 1600 Hz which is divided by 64 in counter U42. The resulting 25 Hz square wave from the +64 output, pin 4 of U42, is the other phase comparator input of U32. The phase lock loop acts to bring the two phase comparator inputs to the same frequency and with zero degrees phase difference. The phase detector of U32 is a digital edge comparison circuit so that the duty cycle of the external input is unimportant. The 25 Hz output from U42 pin 4 at 50% duty cycle is fed to the biquad filter circuit through R100. R100 adjusts the signal level to account for the 50% duty cycle instead of the normal 39% duty cycle.

The circuit of U41, Q9 and CR35 is a lock detector. When the phase lock loop has achieved lock, the front panel PILOT LOCK indicator, CR35, illuminates. During phase lock, the phase pulse (PP) output of U32 at pin 1 has very short negative going pulses at the 25 Hz rate. The width of these pulses is proportional to the phase error between the 25 Hz inputs of the phase comparator. Since U42 clocks on the negative transition of the clock, the phase pulses from PP occur shortly after a negative transition of the VCO output. On the other hand, the D flip flops of U41 latch data on the positive transition of their clocks. Thus, the PP output must remain low for at least 1/2 VCO clock time (from negative to positive transition) in order for U41A to latch a logic low. This corresponds to a phase error of 2.8 degrees. Thus, as long as the phase error is less than 2.8 degrees, the loop is in lock.

If the loop is out of lock, the  $\bar{Q}$  output of U41A will go high presetting U41B. The Q output of U41B will go high turning off Q9 and extinguishing the PILOT LOCK indicator. U41B is clocked at about a 3 Hz rate so that the flicker rate of CR35 is 3 Hz or less.

If lock is lost, positive going pulses will appear at U14A pin 3. R75 and C49 average these pulses causing the voltage at U16 pin 3 to rise above the voltage on pin 2. The open collector output of U16 activates turning off the RF LOCK indicator.

### **3.4.3 Sync Output (reference Figure 3-6)**

For convenience in measuring operating frequency, an unmodulated square wave output is made available from the rear panel SYNC OUTPUT connector. An ECL square wave from U21 pin 3 drives buffer transistor Q3. The collector circuit of Q3 provides a nominal 50 ohm source through DC blocking capacitor C14. When terminated in 50 ohms, the circuit yields a carrier frequency square wave at nominally 0.1 Vp-p.

### **3.4.4 Elliptical Filter and Amplifiers (reference Figure 3-7)**

The RF drive to the transmitter is a square wave phase modulated at the phase angle of the quam modulation from zero degree hybrid U18. The output of U18 is a sum of square waves containing the harmonics of the carrier frequency. Since these harmonics obscure the zero crossings of the quam signal, a limiter will not recover the desired phase modulated square wave. The harmonics must be largely removed so that a limiter can accurately recover the desired square wave. This is the function of the elliptical filter formed by L11 through L14, C36 through C39, and R55 and R111.

The highly accurate square waves used in modulators U19 and U20 produce negligible even harmonics easing the filter requirements. The filter must reject the third and higher odd harmonics. This allows use of five filters to cover the broadcast band. The operating frequency is at least 100 kHz below the filter corner where the amplitude slope and changes in phase slope are gradual. As the filter corner is changed for each band, the filter impedance is scaled to keep L11 through L14 the same for each band. The source impedance is the 50 ohm output of U17 summed with R111. The load impedance is R55 in parallel with R49.

Amplifier U17 provides a nominal 50 ohm load to hybrid U18, provides a nominal 50 ohm source impedance, and boosts the signal level by 8 dB. Amplifier U5 increases the signal level by 20 dB for limiter U6. The signal at TP5, called the QUAM POINT, is a clean quam signal without harmonics.

### **3.4.5 Limiter and TTL Line Driver (reference Figure 3-7)**

The clean quam signal from amplifier U5 is amplitude limited by one half of line receiver U6. The other half of U6 is not used. The output of U6 at pin 4 is a TTL level square wave recovered from the zero crossings of the quam signal. The input offset trimmer, R51, is factory adjusted to minimize phase modulation of the TTL output with L+R only modulation (L-R=0 and no phase modulation).

The TTL level signal from U6 is buffered by U2B, one of the quad line drivers of U2. The output of U2B is connected to the input of the other three line drivers and provides the signal for U3A and U3C of the high level output option. The outputs of U2A, U2C and U2D are paralleled for increased drive and appear at the rear panel TTL OUTPUT connector, J2. This signal is intended to drive a coaxial cable terminated in 50 or 75 ohms (characteristic impedance of the coaxial cable) providing a TTL signal to suitably equipped transmitters.



### 3.4.6 High Level Output Option (reference Figure 3-7)

For stereo operation of transmitters with class C tuned, vacuum tube stages between the crystal oscillator and final amplifier, a higher level drive is required to the grid circuit of one of these class C amplifiers. The high level output from J3, the rear panel HIGH LEVEL OUTPUT connector, is connected through a coaxial cable to a termination resistor and a DC blocking capacitor to the grid of the class C amplifier, usually the one immediately following the crystal oscillator. The high level output can provide up to 35 Vp-p square wave. If higher levels are required, a transformer or tuned  $\pi$  network may be employed to boost the level as described in Section 5.

The TTL level signal from U2B is buffered by U3A and U3B driving the inputs of U4A through U4C. The TTL level signal from U2B is also inverted by U3C and buffered by U3D driving the inputs of U4D through U4F. The hex inverters of U4 have open collector outputs which, operating in conjunction with R42, R43, R48 and C23, produce 10 Vp-p square waves. These square waves are coupled through DC blocking capacitors C21 and C22 to the gates of Q2 and Q1. Since the two square waves are 180 degrees out of phase, Q1 and Q2 are alternately switched on for push-pull operation. The drain currents of Q1 and Q2 are converted from push-pull to an unbalanced output by transformer A1T1. The output level is controlled by the DC voltage on the center tap of T1. Front panel RF LEVEL control, R328, adjusts the output of voltage regulator VR7 controlling this DC voltage.

### 3.5 ASE-2 POWER SUPPLY (reference Figure 3-8)

AC main power is connected to the exciter at the rear panel line filter FL1 as shown in schematic diagram Figure 3-8. Line current flows through fuse F1 and the primary circuit of power transformer T1. The power transformer primary may be wired for either 120 VAC or 240 VAC operation (D15-20-1 through -4) or the primary may be wired for either 100 VAC or 200 VAC operation (D15-20-5 through -8) as described in Table 1-1. The primary connection is indicated on the rear panel just below the line filter. For safety, all AC line voltage connections are hard wired to the line filter and the fuse holder using heat shrink tubing to minimize shock hazard.

The dual 18 VAC secondary of power transformer T1 is connected to the printed circuit board at J6-1 through J6-5 providing current for bridge rectifier CR5. Positive charge current flows through R89 to filter capacitor C28. This powers +15 VDC regulator VR1 and +5 VDC regulator VR3. Negative charge current flows from CR5 through R88 to filter capacitor C31 powering -15 VDC regulator VR2. Regulators VR1, VR2 and VR3 are set to voltage by factory adjustment of R3, R87 and R118 respectively. If any of these regulators are replaced, the associated variable resistor must be adjusted to bring the replaced regulator to within  $\pm 10$  mV of the nominal output voltage.

Although regulators VR1, VR2 and VR3 have sufficient current capacity to supply the entire unit, VR4 through VR6 are added to power optional circuits in order to reduce heatsinking requirements for VR1 through VR3. These regulators are considered part of the option and, therefore, are only installed if the optional circuit is installed. Since the supply voltage to the high level output option is not critical, fixed regulators are used. The two +5 VDC regulators, VR3 and VR6, have input dropping resistors R312 and R314 to reduce power dissipation in the regulator.

## 3.4 ASE-2 RADIO FREQUENCY CIRCUITS

Refer to the functional block diagram, Figure 3-1, and schematic diagrams Figure 3-6 and Figure 3-7 in the following descriptions.

### 3.4.1 Quam Modulator (reference Figure 3-6)

The crystal oscillator of Y1 and Q8 operates at four times the radio station carrier frequency. The oscillator frequency is adjusted by C64 located near the crystal as shown in Figure 7-1. This oscillator signal clocks an ECL dual D flip flop, U21. These flip flops are connected to produce a set of carrier frequency square waves in quadrature. The square wave from U21 pin 2 and its inverse on pin 3 provide an in-phase carrier for modulator U19. The square wave from U21 pin 15 and its inverse from pin 14 provide a quadrature carrier for modulator U20. Each modulator has an offset adjustment and the quadrature modulator has a gain adjustment to set its gain the same as the in-phase modulator gain. The offset adjustments of R146 and R149 are factory set so that the modulators produce no RF output when no modulating signals (audio or DC) are present. The modulator gain control for U20, R148, is factory set so the sidebands during L-R modulation are identical to the sidebands produced by an identical percentage of 1+L+R modulation from U19. The outputs of the two modulators are isolated and combined by zero degree hybrid U18. The output of U18 is a quam signal which is formed by modulated square waves and therefore includes the square wave harmonics of the carrier.

### 3.4.2 Synchronous Transmitter Option - RF Circuit (reference Figure 3-6)

In operation of a synchronous transmitter system, the crystal oscillator must be locked to an external RF source so that all transmitters in the synchronous transmission system are at the same frequency. The external carrier frequency RF reference is connected to the rear panel RF INPUT connector. R64 terminates this input nominally to 50 ohms. An input protective network consisting of C46, R71, CR13 and CR14 protects the input of ECL line receiver U15. The three stages of this differential line receiver are cascaded to produce an ECL square wave output. Jumper W2 is normally set from 1 to 2 so that the signal from U21 pin 2 is in phase with the RF INPUT. Setting W2 to the 2 to 3 position allows 180 degree lock between these two signals to allow for an even or odd number of RF stages in the transmitter.

The ECL level square wave from W2 pin 2 is the reference signal (R) for ECL phase/frequency comparator U8. The variable frequency (V) input of U8 comes from the carrier frequency output of U21 pin 2. The up (U) and down (D) outputs of U8 are connected to the loop filter circuit of U7. The loop adjusts the voltage at the output of U7 to lock the frequency and phase of the exciter's carrier to the RF INPUT by varying the capacitance of CR27, a voltage variable capacitor diode. With the synchronous transmitter option, C63 is changed to 10 pF and C64 is adjusted for +6 VDC at the output of U7 when the RF INPUT frequency is correct.

The circuit of U14, U16 and CR36 is a lock detector. The exclusive OR gate of U14A is connected to the R and V inputs of phase/frequency detector U8. As long as lock is maintained, the output of U14A pin 3 will be logic low. The output of U14B at pin 10 is also logic low. Because of the feedback action of R83 and R76, the positive input of U16, pin 2, will be slightly higher than the negative input at pin 3. U16 is a voltage comparator with an open collector output. In lock, the open collector output is inactive and the current from R84 illuminates CR36, the front panel RF LOCK indicator.

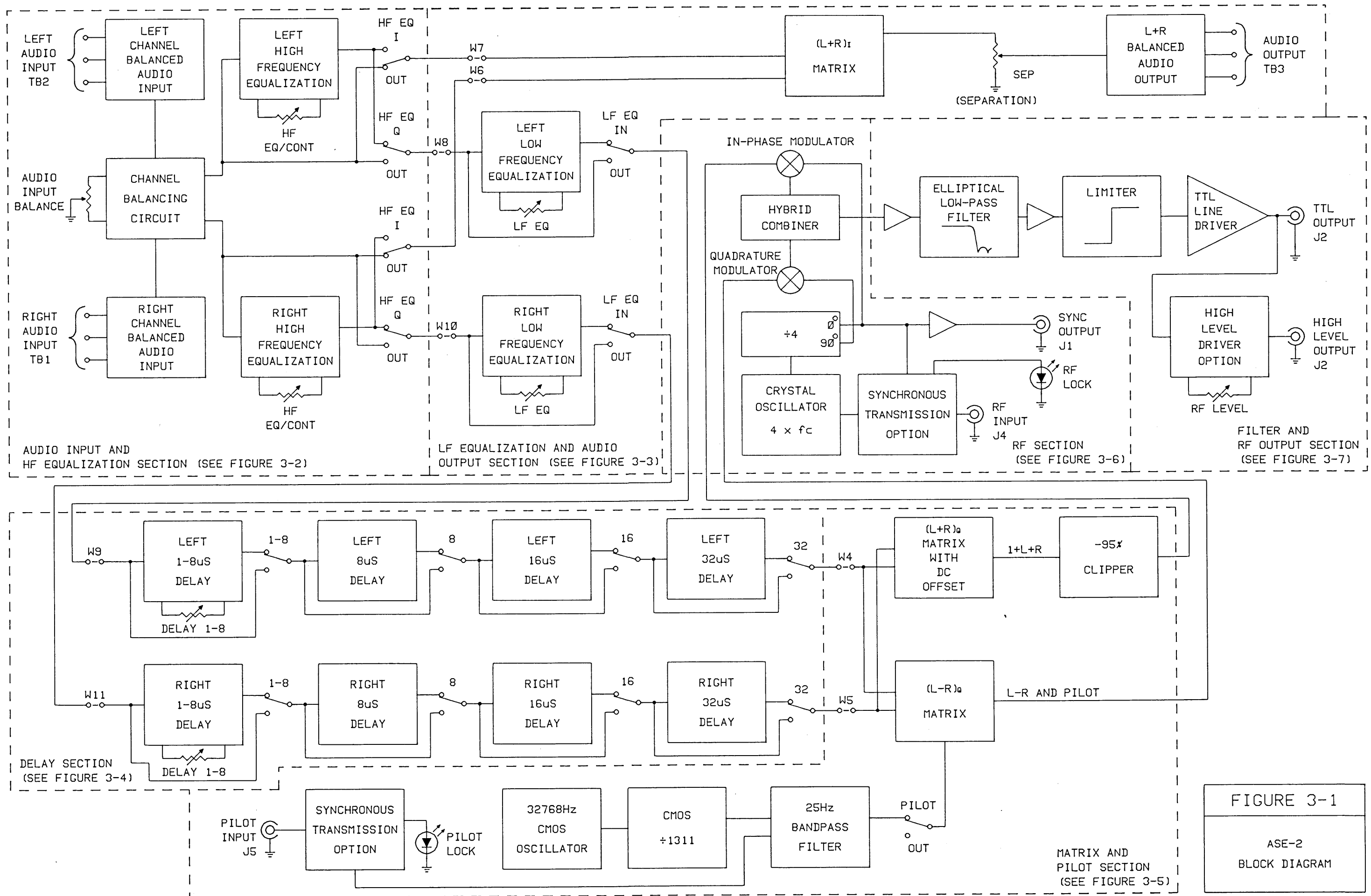


FIGURE 3-1  
ASE-2  
BLOCK DIAGRAM

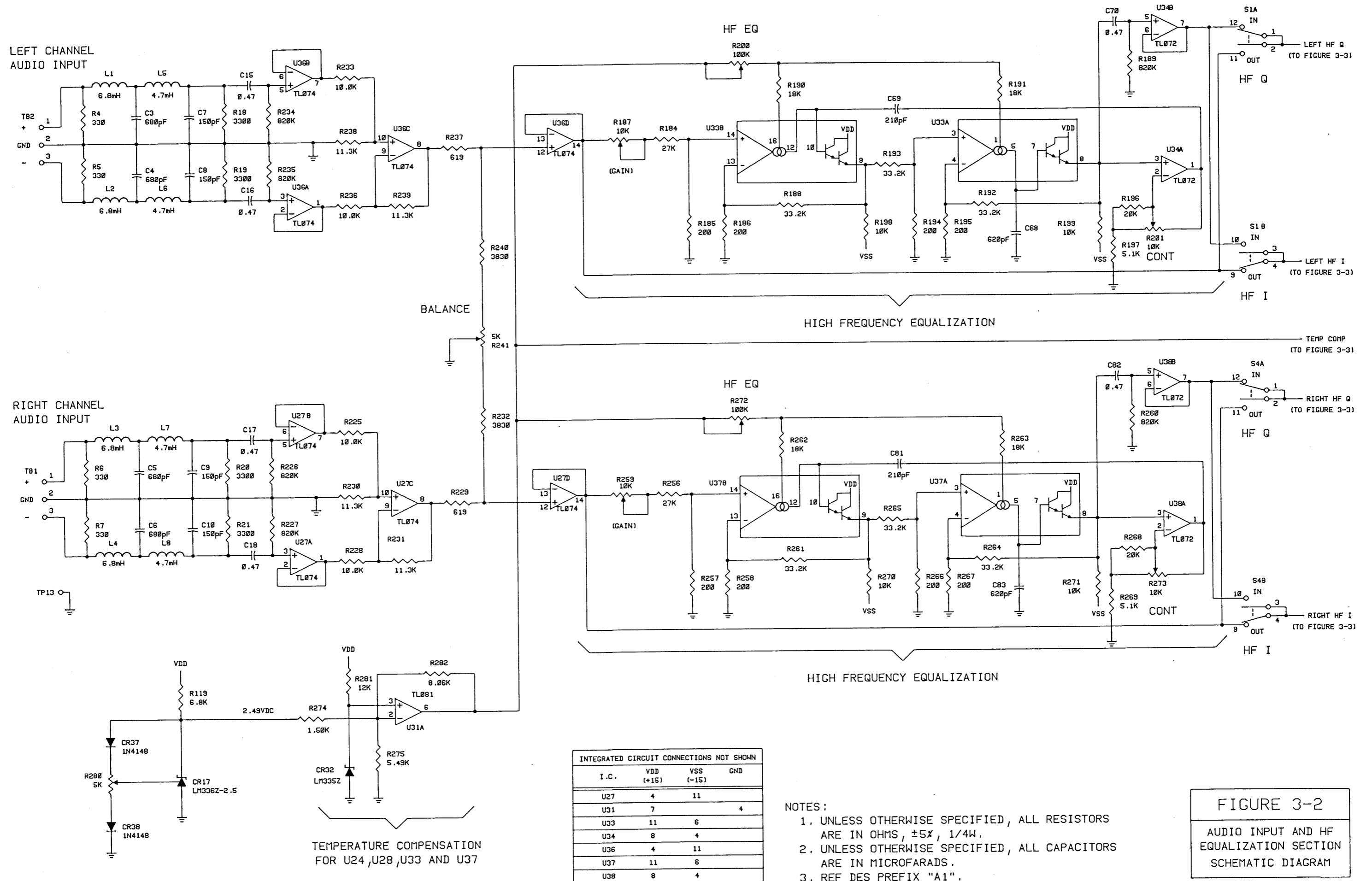
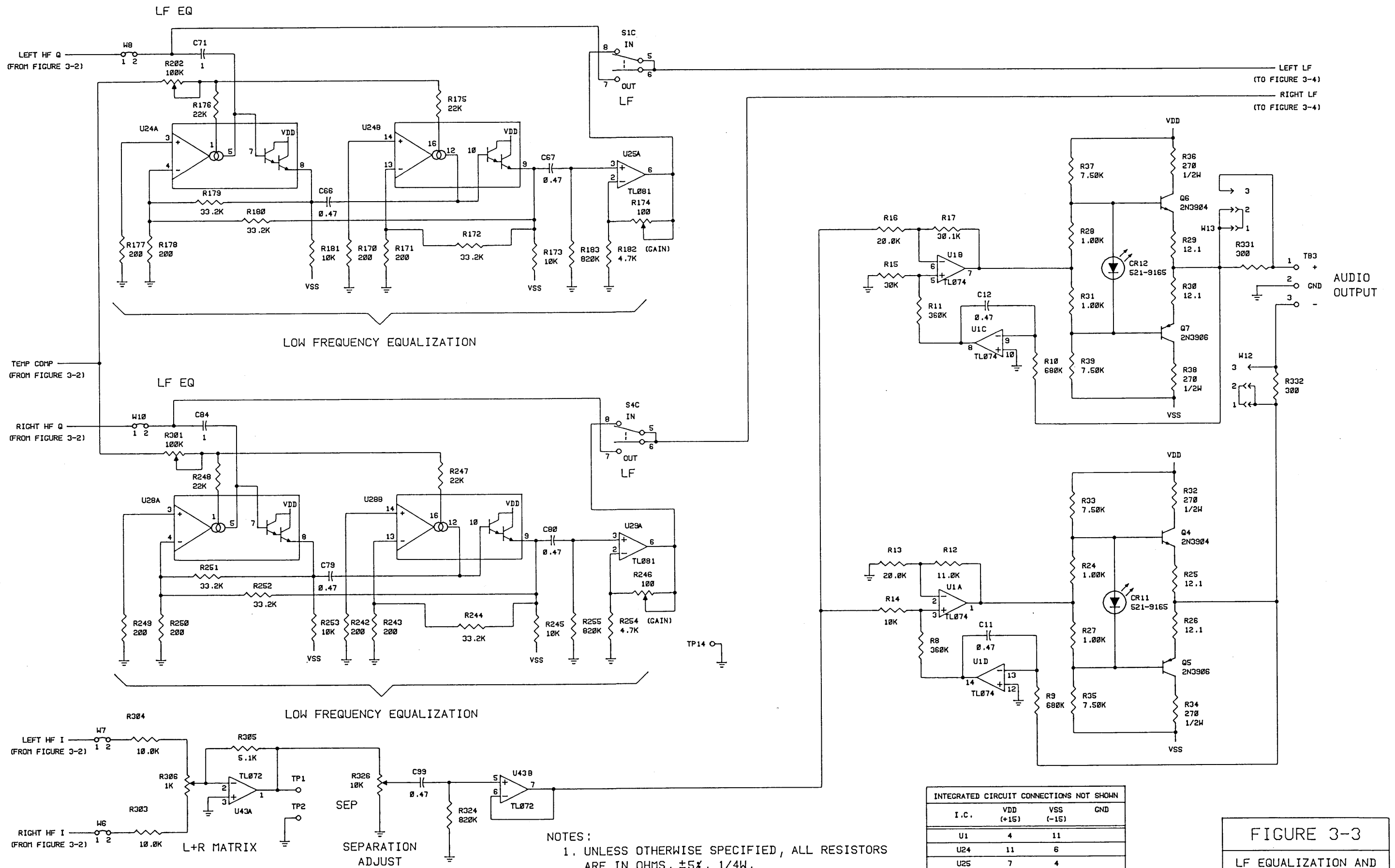


FIGURE 3-2  
AUDIO INPUT AND HF  
EQUALIZATION SECTION  
SCHEMATIC DIAGRAM

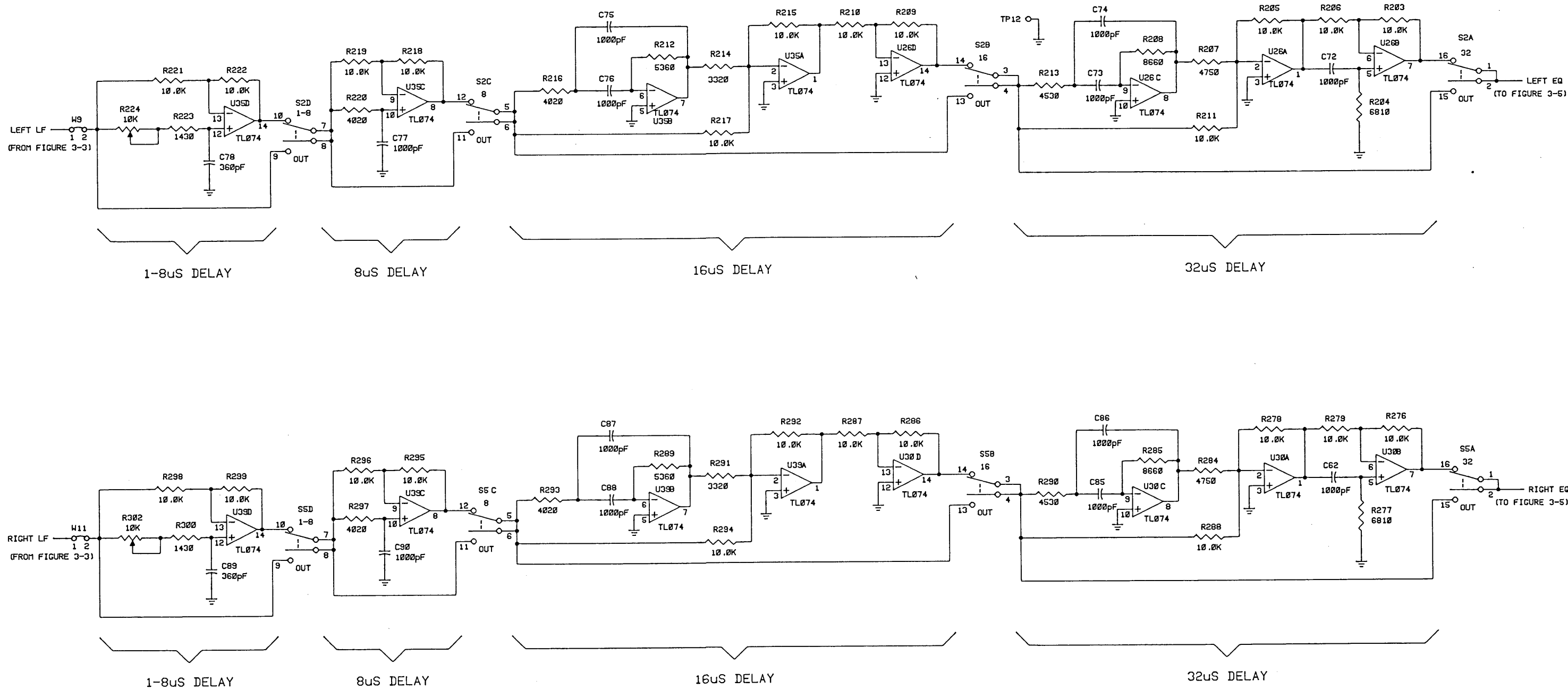


- NOTES:
1. UNLESS OTHERWISE SPECIFIED, ALL RESISTORS ARE IN OHMS,  $\pm 5\%$ , 1/4W.
  2. UNLESS OTHERWISE SPECIFIED, ALL CAPACITORS ARE IN MICROFARADS.
  3. REF DES PREFIX "A1".

INTEGRATED CIRCUIT CONNECTIONS NOT SHOWN

I.C.	VDD (+15)	VSS (-15)	GND
U1	4	11	
U24	11	6	
U25	7	4	
U28	11	6	
U29	7	4	
U43	8	4	

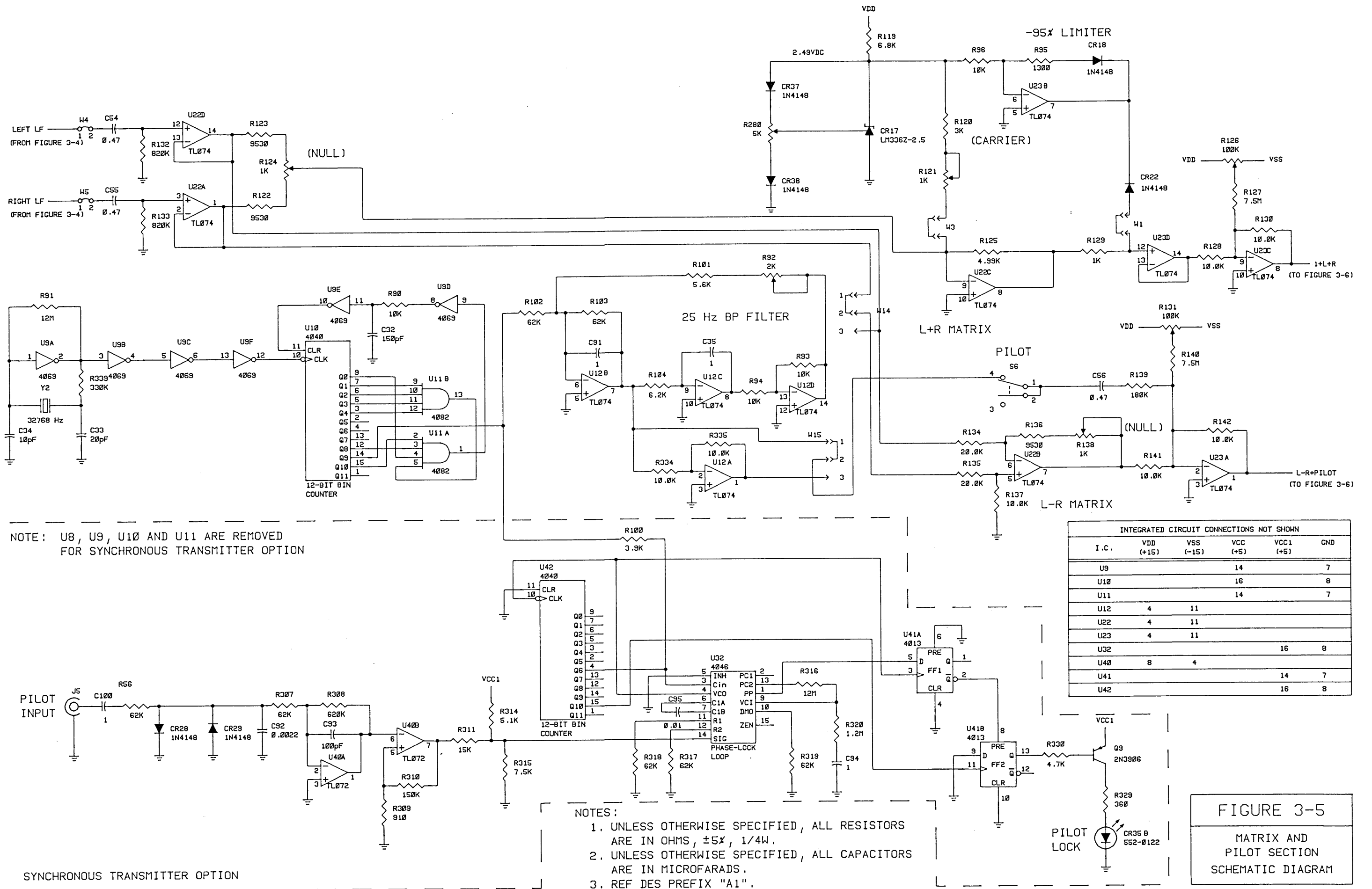
FIGURE 3-3  
LF EQUALIZATION AND AUDIO OUTPUT SECTION SCHEMATIC DIAGRAM

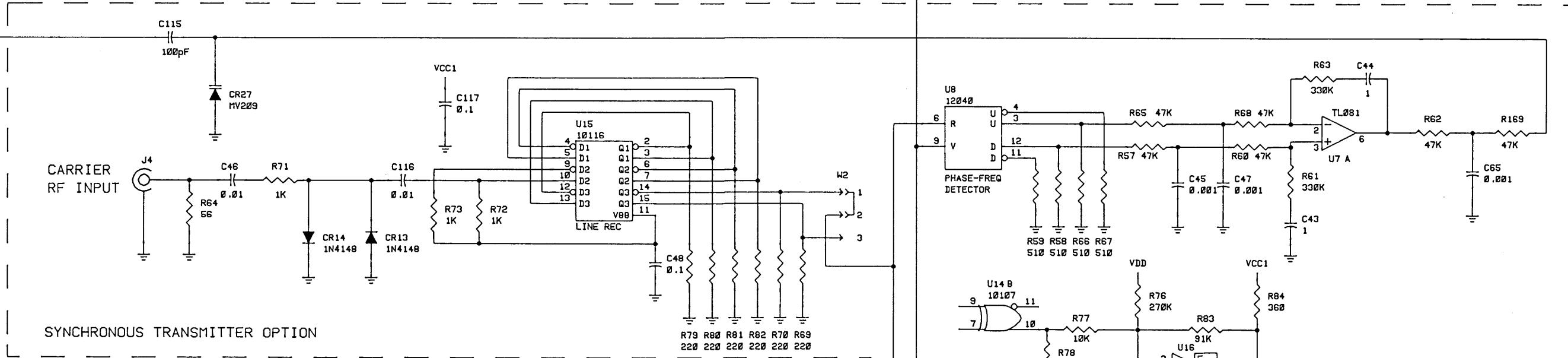
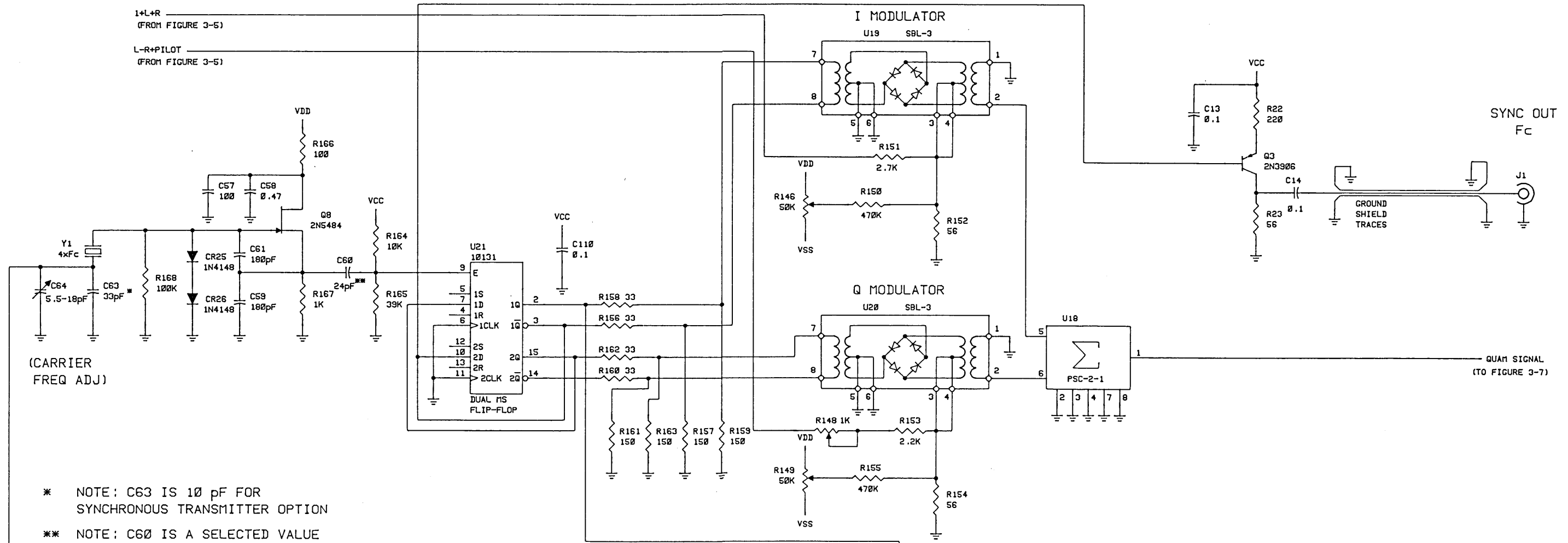


- NOTES:
1. UNLESS OTHERWISE SPECIFIED, ALL RESISTORS ARE IN OHMS,  $\pm 5\%$ , 1/4W.
  2. UNLESS OTHERWISE SPECIFIED, ALL CAPACITORS ARE IN MICROFARADS.
  3. REF DES PREFIX "A1".

INTEGRATED CIRCUIT CONNECTIONS NOT SHOWN			
I.C.	VDD (+15)	VSS (-15)	GND
U26	4	11	
U30	4	11	
U35	4	11	
U39	4	11	

FIGURE 3-4  
DELAY SECTION  
SCHEMATIC DIAGRAM





INTEGRATED CIRCUIT CONNECTIONS NOT SHOWN

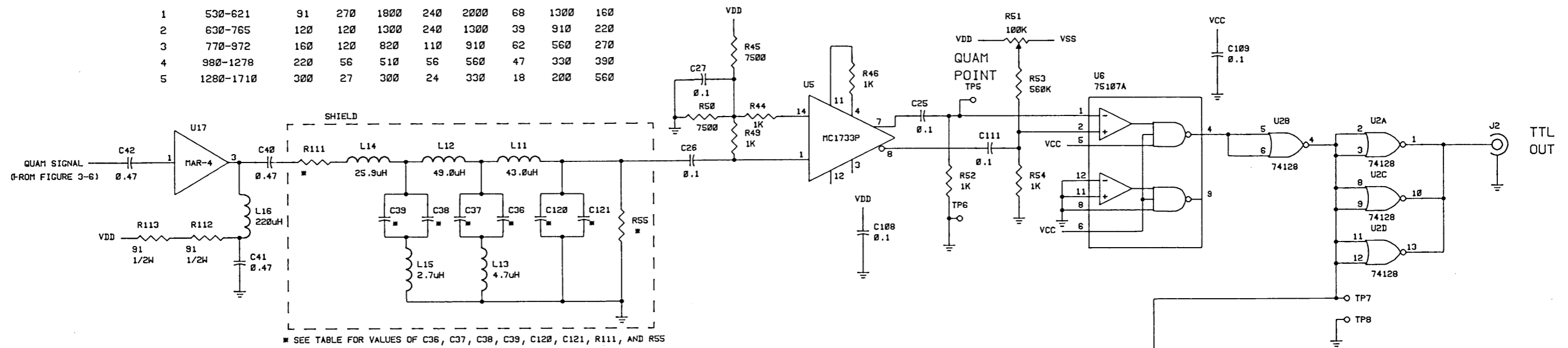
I.C.	VDD (+15)	VSS (-15)	VCC (+5)	VCC1 (+5)	GND
U7	7				4
U8			1,14		7
U14			1,16		8
U15			1,16		8
U16	8				4
U21			1,16		8

- NOTES:
- UNLESS OTHERWISE SPECIFIED, ALL RESISTORS ARE IN OHMS,  $\pm 5\%$ , 1/4W.
  - UNLESS OTHERWISE SPECIFIED, ALL CAPACITORS ARE IN MICROFARADS.
  - REF DES PREFIX "A1".

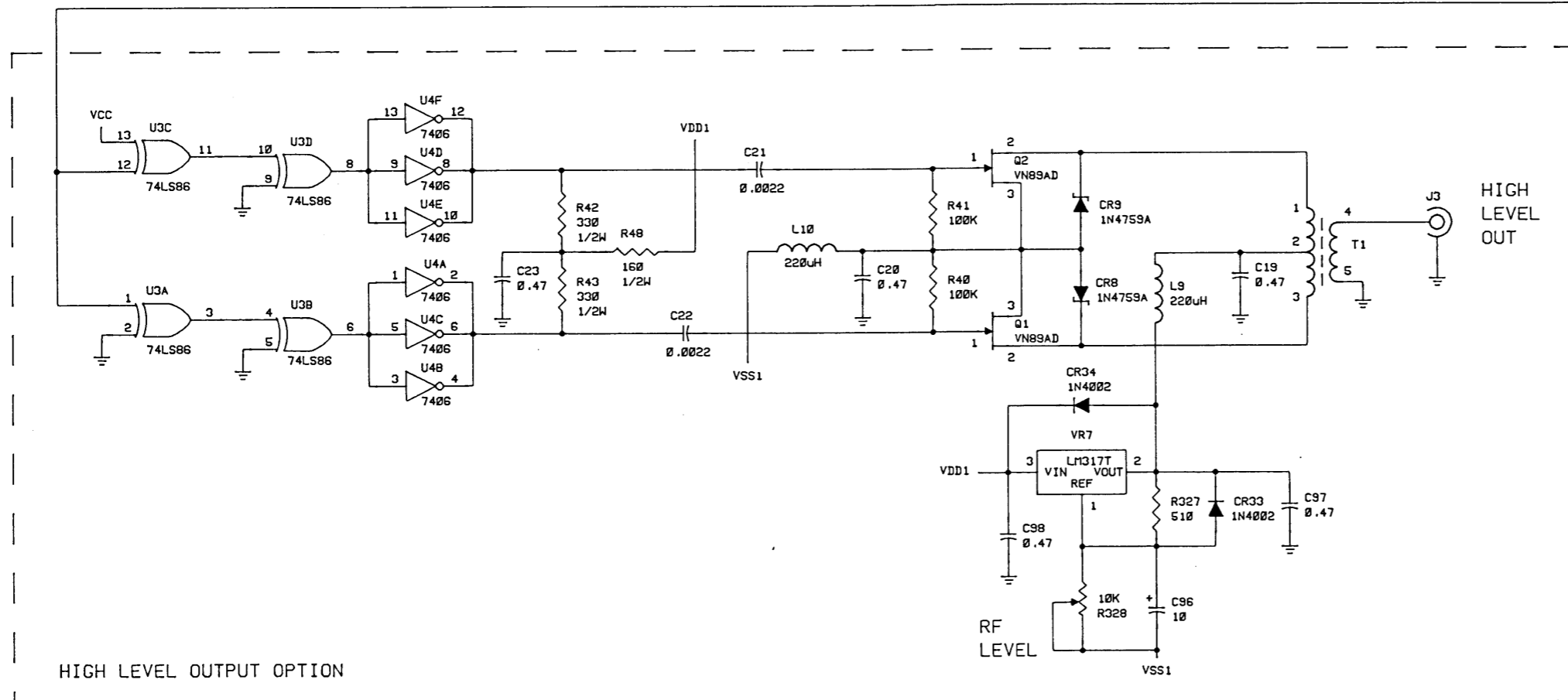
FIGURE 3-6  
RF SECTION  
SCHEMATIC DIAGRAM



BAND	FREQ RANGE	R111	C38	C39	C36	C37	C120	C121	R55
1	530-621	91	270	1800	240	2000	68	1300	160
2	630-765	120	120	1300	240	1300	39	910	220
3	770-972	160	120	820	110	910	62	560	270
4	980-1278	220	56	510	56	560	47	330	390
5	1280-1710	300	27	300	24	330	18	200	560



\* SEE TABLE FOR VALUES OF C36, C37, C38, C39, C120, C121, R111, AND R55

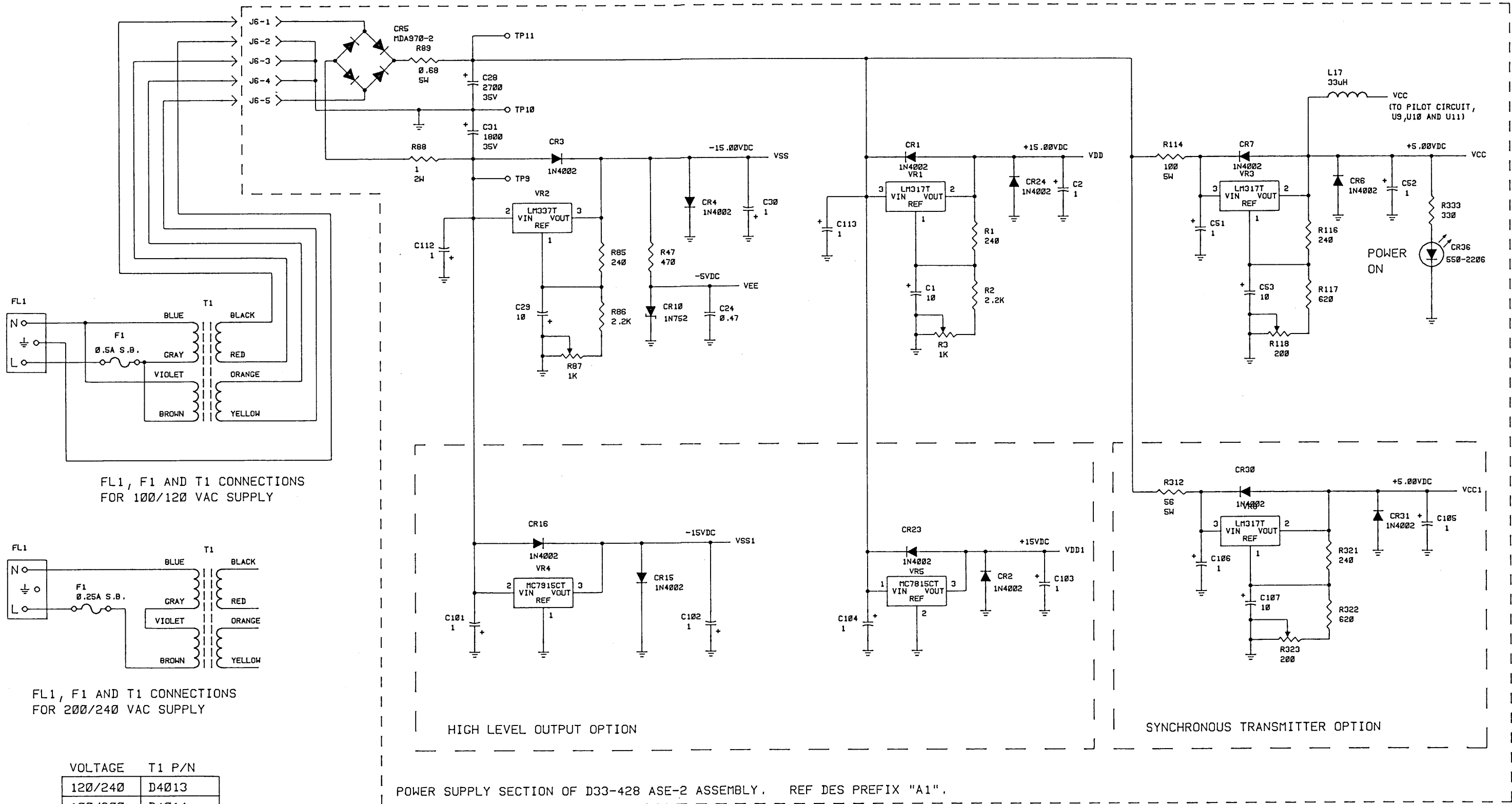


HIGH LEVEL OUTPUT OPTION

INTEGRATED CIRCUIT CONNECTIONS NOT SHOWN					
I.C.	VDD (+15)	VSS (-15)	VCC (+5)	VEE (-5)	GND
U2			14		7
U3			14		7
U4			14		7
U5	10				5
U6			14	13	7
U17					2,4

- NOTES:
1. UNLESS OTHERWISE SPECIFIED, ALL RESISTORS ARE IN OHMS,  $\pm 5\%$ , 1/4W.
  2. UNLESS OTHERWISE SPECIFIED, ALL CAPACITORS ARE IN MICROFARADS.
  3. REF DES PREFIX "A1".

FIGURE 3-7  
FILTER AND RF OUTPUT SECTION SCHEMATIC DIAGRAM



- NOTES:
1. UNLESS OTHERWISE SPECIFIED, ALL RESISTORS ARE IN OHMS,  $\pm 5\%$ , 1/4W.
  2. UNLESS OTHERWISE SPECIFIED, ALL CAPACITORS ARE IN MICROFARADS.

FIGURE 3-8  
POWER SUPPLY SECTION  
SCHEMATIC DIAGRAM

## SECTION 4

### INSTALLATION

#### 4.1 INTRODUCTION

This section describes the steps necessary to install a Model ASE-2 AM Stereo Exciter with an AM broadcast transmitter. This includes the electrical connections between the ASE-2 and the transmitter and the electrical connections between the ASE-2 and the audio processing equipment. Section 5 describes the adjustment of the ASE-2, the transmitter and the audio processor for best stereo performance.

#### CAUTION

*The AM stereo exciter contains parts sensitive to damage by electrostatic discharge (ESD). Use ESD precautionary procedures when touching, removing, or inserting parts in the ASE-2.*

Upon receipt of the ASE-2 equipment, unpack all components and inspect carefully for any damage that may have occurred in shipment. Remove the top cover of the ASE-2 and verify that all socketed components and removable jumpers are properly seated.

#### 4.2 RACK MOUNTING

The Model ASE-2 fits in a standard 19 inch (48.26 cm) wide EIA rack and is 1.75 inches (4.45 cm) high (one rack unit high). The ASE-2 is usually installed in the same rack with the stereo audio processor so that audio wiring runs are minimized. The unit should not be mounted near other equipment that produces excessive heat or RF fields.

If strapping the chassis to the station's RF ground system is desirable, a ground strap can be connected at the rear of each side panel with 10-32 screws. The side panel is electrically conductive.

#### 4.3 AC POWER CONNECTIONS

Before installing the Model ASE-2, examine the rear panel of the ASE-2 below the line filter input. The rear panel is labeled with two boxes indicating 120 VAC or 240 VAC connection of the power transformer. A blue adhesive dot or a mark has been placed in the appropriate box to indicate the line voltage for which the ASE-2 is wired. Units wired for 100 VAC or 200 VAC will have an adhesive label indicating their operating voltage. The ASE-2's operating voltage may also be determined by the Delta part number and by the fuse size. As shown in Table 1-1, an ASE-2 wired for 120/240 VAC operation has a part number D15-20-1 through -4 while an ASE-2 wired for 100/200 VAC operation carries a part number D15-20-5 through -8. An ASE-2 wired for 200 VAC or 240 VAC operation will have a 1/4 ampere fuse while an ASE-2 wired for 100 VAC or 120 VAC operation will have a 1/2 ampere fuse.

Check that the fuse size and equipment dash number are consistent with the line voltage label. To verify the ASE-2 operating voltage, remove the top cover and identify the transformer part

number and primary wiring against Figure 3-8. Make sure that the rack's line voltage is the same as the ASE-2 wiring.

The AC power cable connects to the 100/120/200/240 VAC 50/60 Hz main power. The detachable power cord supplied with the ASE-2 is fitted with a Standard North American male connector. Standard color codes for the individual conductors are brown = line, blue = neutral and green/yellow = ground. Alternate conductor codings are black = line, white = neutral and green = ground.

#### **4.4 LEFT AUDIO INPUT AND RIGHT AUDIO INPUT**

Connect the left channel balanced output of the audio processor to the left channel balanced input, TB2, of the ASE-2. Maintain correct polarity by connecting the positive output (+) to the positive input (+) and the negative output (-) to the negative input (-). Similarly, connect the right channel balanced output of the audio processor to the right channel balanced input, TB1, of the ASE-2. Use shielded twisted pair audio cable such as Belden 8451 with the shields connected at both ends.

For testing and adjustments of the various front panel controls of the ASE-2, the audio inputs will be temporarily disconnected as discussed in Section 5. If the audio input cables are not short runs from the audio processor, label the removable headers of the audio input connectors to identify their mating connector, TB1 or TB2.

Note that during final testing, the polarity of both audio inputs may be reversed to maximize positive asymmetrical modulation. The unit should never be operated with only one audio input reversed since the stereo subchannel (L-R) would then appear on the envelope.

#### **4.5 AUDIO OUTPUT**

Before connecting the audio output to the transmitter, set the front panel SEP (separation) control fully counterclockwise. This 15 turn potentiometer sets the audio level to the transmitter's modulator for maximum stereo separation. Placing this control in the fully counterclockwise position guarantees that the transmitter's modulator will not be inadvertently over driven during initial testing.

Connect the ASE-2 balanced audio output, TB3, to the transmitter's audio input observing correct polarity. Use shielded twisted pair audio cable such as Belden 8451 with the shields connected at both ends. Route the audio cable to avoid induced currents from high power RF and power line cables. Label the removable header from the audio output connector to indicate its mating connector, TB3.

Note that the polarity of the audio signal to the transmitter's modulator may be reversed later in testing for correct envelope polarity with phase modulation. If additional audio drive is required or if the transmitter has a lower impedance input, internal jumpers W12 and W13 should be placed in the 2-3 position. The location of these jumpers is shown in Figure 7-1.

#### 4.6 SYNCHRONOUS TRANSMITTER OPERATION (OPTION)

Stations operating with synchronous transmitters must use a Model ASE-2 equipped for synchronous operation. The nameplate will be marked with part number D15-20-3, D15-20-4, D15-20-7 or D15-20-8. Connect the carrier frequency reference signal to J4, RF INPUT. This signal must have the characteristics described in Section 2. J4 has a nominal 50 ohm input impedance. The front panel RF LOCK indicator should illuminate within 5 seconds, verifying that the internal crystal oscillator is phase locked to the reference signal.

Connect the 25 Hz pilot reference signal to J5, PILOT INPUT. This signal must have the characteristics described in Section 2. J5 is a high impedance input. The front panel PILOT LOCK indicator should illuminate continuously in approximately 30 seconds indicating that the internal pilot PLL is phase locked to the reference signal.

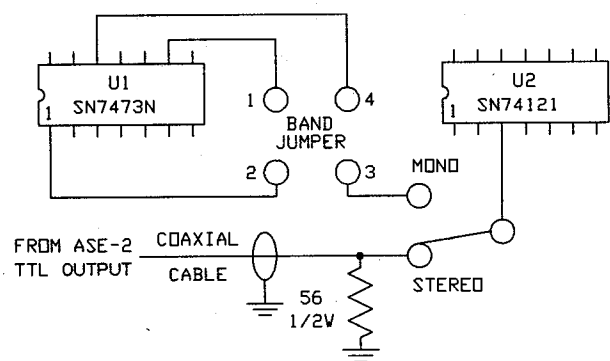
#### 4.7 SYNC OUTPUT

The SYNC output, J1, is an unmodulated carrier frequency signal useful for frequency monitoring. This output may be connected to a frequency counter using coaxial cable. If a long coaxial cable run is required, terminate the coaxial cable in its characteristic impedance. J1 is a nominal 50 ohm source.

#### 4.8 TTL OUTPUT

Most newer transmitters employ a TTL divider circuit somewhere in the early RF stages or provide a TTL level input port for an AM stereo exciter. Use of TTL drive is preferable to high level drive on a later RF stage because TTL drive virtually guarantees that the transmitter's spurious outputs at the harmonics of the carrier remain at the level of the unmodified transmitter.

Figure 4-1 is a simplified schematic diagram of a TTL drive to a Continental Model 315-R1 transmitter. Notice that a switch is installed to allow easy selection between monophonic and stereo operation. The 56 ohm 1/2W resistor terminates the coaxial cable.



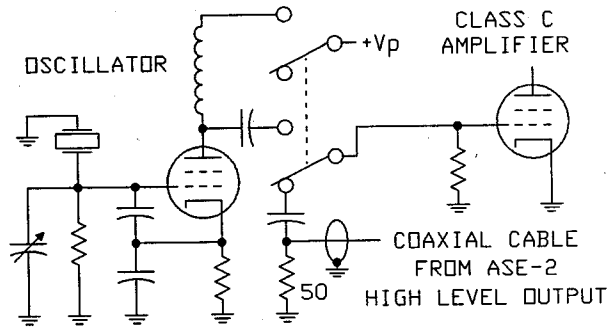
**Figure 4-1**  
**TTL Interface**

#### 4.9 HIGH LEVEL OUTPUT (OPTION)

Older transmitters use vacuum tube oscillators followed by tuned class C amplifier stages. The High Level Output of the ASE-2 is connected to drive the grid of the first amplifier stage following the oscillator. Figure 4-2 shows such an arrangement with a switch, a DC blocking capacitor and a termination resistor. Notice that in some cases it is necessary to employ a second pole of the switch to disable the transmitter's crystal oscillator to avoid a carrier beat. The front panel RF Level control

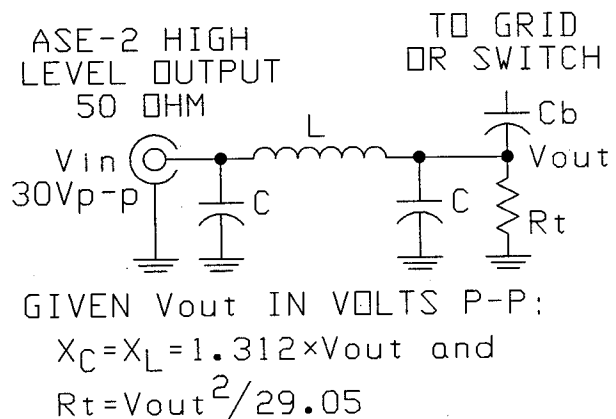
is adjusted to produce the same peak-to-peak drive to the grid as was supplied by the crystal oscillator.

Many transmitters have two crystal oscillators and an oscillator selector switch. In this case, the second oscillator tube and crystal are removed and the ASE-2 High Level Output is connected to the tube socket with a termination resistor and DC blocking capacitor. The circuit can be constructed in a minibox with a mating plug for the tube socket so that no transmitter modification is necessary. Care should be exercised to ensure that the termination resistor is non-inductive and is properly heatsinked to the case since this resistor may dissipate as much as 6.8 watts. Delta recommends Caddock type MP330 resistors. Also ensure that the DC blocking capacitor has sufficient rating to handle the maximum DC plate voltage plus the peak signal voltage.



**Figure 4-2**  
**High Level Interface**

The High Level Output can produce up to a 35 Vp-p square wave. Some older transmitters, however, require higher grid drive voltage. One simple method of generating this higher voltage is by use of a step up RF transformer. Another method uses an impedance transforming  $\pi$  network. Since the low pass configuration of the  $\pi$  network reduces carrier harmonics, the output of this circuit more closely duplicates the output waveform of the crystal oscillator. Figure 4-3 shows a 90 degree  $\pi$  network with design equations.



**Figure 4-3**  
 **$\pi$  Matching Network**

For best results, use mica capacitors, an air wound or high Q toroidal coil and a non-inductive termination resistor. The coil and capacitors should be carefully measured and the circuit should be tuned at carrier frequency on the laboratory bench before installation. Be sure that the resistor has sufficient power rating and is properly heatsinked.

Notice: For the Harris MW-50, the oscillator cage is floating at a dangerously high voltage. The RF from the exciter should be coupled through Harris interface kit 994-8749-001 for isolation.

## SECTION 5

### EQUIPMENT PERFORMANCE ADJUSTMENTS

#### 5.1 INTRODUCTION

This section describes equipment adjustments of the Model ASE-2, the transmitter and the audio processor for best stereo performance. These adjustments are made after the installation described in Section 4 is complete. The same adjustments should also be done, as necessary, to restore optimum stereo operation during an annual or semi-annual performance evaluation.

#### 5.2 STEREO MODULATION MONITOR

Although the Federal Communications Commission no longer requires the use of a modulation monitor, Delta believes that employing a stereo modulation monitor is good engineering practice. A stereo modulation monitor is not only an instrument for monitoring peak modulation level but is also a high performance measurement instrument for determining system performance with test modulation. A stereo modulation monitor, such as the Delta Model ASM-1, has far greater stereo performance than a stereo radio receiver. Thus, the transmitter is usually the limiting factor in stereo performance measurements.

#### 5.3 NEUTRALIZATION AND TRANSMITTER TUNING

Two factors that limit stereo performance are the transmitter's incidental phase modulation (IPM) and incidental amplitude modulation (IAM). As a rule of thumb, in the absence of high levels of hum or distortion, the stereo separation is approximately equal to the crosstalk between the main channel (L+R) and subchannel (L-R). Therefore, these two factors should be measured and the transmitter should be adjusted to minimize their effect. A stereo modulation monitor is useful for both measurements. Since the main channel is on the envelope and the subchannel is purely phase modulation, measurement of L-R/L+R and L+R/L-R crosstalk, the IPM and IAM respectively, is a direct measure of the performance limits of the transmitter.

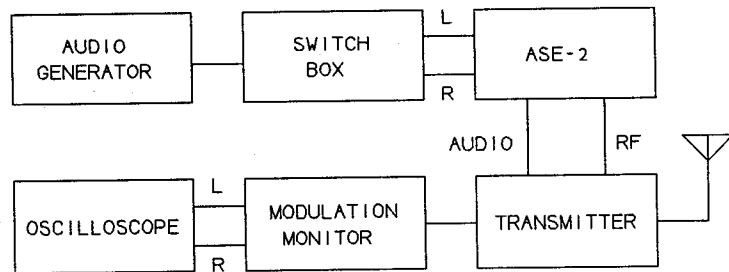
For measurement of IAM, temporarily disconnect the audio feed to the transmitter's modulator and connect an audio source at 1 kHz so that the left channel exciter input is a reversal of the right channel input (L=-R). Adjust the audio level until the modulation monitor indicates L-R=100%. The modulation monitor indicates the level of IAM on the L+R meter. Slight adjustments of the transmitter's tuned circuits on the efficient side of the peak will minimize IAM.

Usually, the IAM level is well below the IPM level and, therefore, IPM limits separation. To measure IPM, switch the transmitter to operate from its internal crystal and parallel connect the left and right audio inputs of the ASE-2 to a 1 kHz audio source (L=R). With the audio feed to the transmitter's modulator reconnected, adjust the audio level for 85% L+R (envelope modulation). The modulation monitor's L-R-meter is an indication of IPM. Adjust the transmitter's neutralization control for minimum IPM. Many transmitters have insufficient neutralization and additional capacitors must be installed. The transmitter manufacturer should be consulted about suitable neutralization schemes. Installation of doorknob capacitors, a vacuum variable capacitor or a clamshell arrangement may be appropriate and the required components may be readily available from the transmitter manufacturer.

The IPM level should also be checked at lower modulating frequencies, such as 50 or 100 Hz. If IPM levels are substantially higher than the level at 1 kHz, the culprit is probably power supply sag affecting the lower level RF stages. Replacement of old electrolytic filter capacitors usually cures this problem. In some instances, neutralization of the RF driver stage will improve IPM.

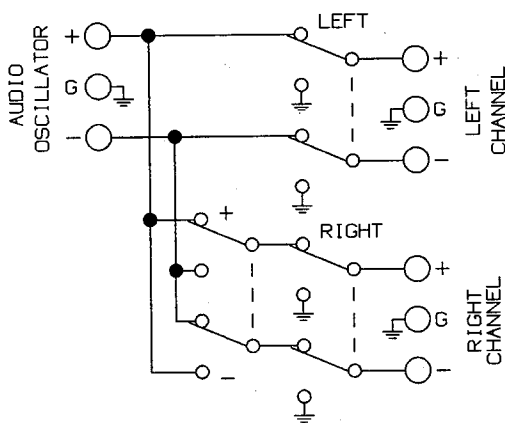
## 5.4 TEST SETUP

Figure 5-1 shows a test setup for adjustment of the transmitter and the Model ASE-2. The audio generator must have a balanced, low distortion output. The audio switch box (described below) allows easy switching between main channel, subchannel and single channel operation. An AM stereo modulation monitor such as a Delta Model ASM-1 takes an RF sample from the transmitter output. Most transmitters have a modulation monitor sample port. A dual trace oscilloscope shows the left and right channels on an X-Y display. In the oscilloscope displays shown below, left channel only modulation is shown and the waveform is oriented predominantly along the horizontal axis. For right channel only displays, the waveforms will be oriented along the vertical axis.

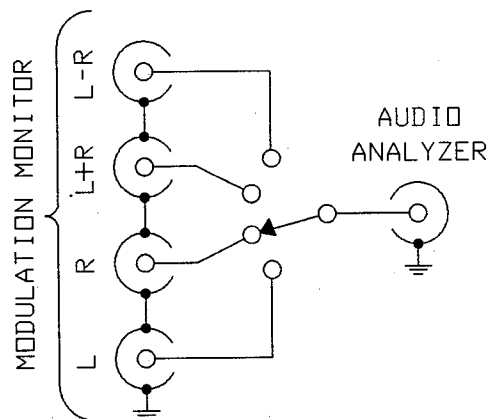


**Figure 5-1**  
**Test Setup**

Switch boxes for generating and monitoring audio test tones can be constructed. The switch box in Figure 5-2 generates the audio for the L and R balanced inputs to the ASE-2 from a single balanced source. It generates L+R, L-R, L only or R only. The switch box of Figure 5-3 switches between the four BNC outputs on the stereo modulation monitor Model ASM-1.



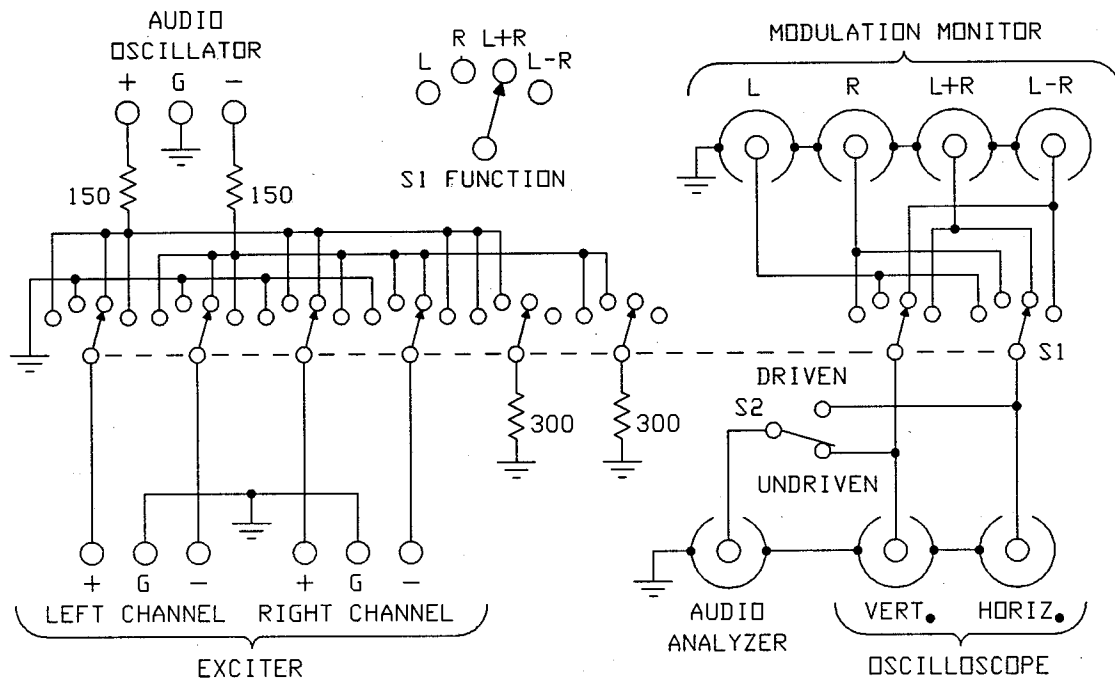
**Figure 5-2**  
**Exciter Switch Box**



**Figure 5-3**  
**Monitor Switch Box**

Optionally, the switch boxes can be combined as shown in Figure 5-4. This switch box configuration combines the generating and monitoring switches so that one switch controls both the audio to the exciter and the corresponding outputs of the modulation monitor. Notice that this switch box has outputs for an X-Y display on an oscilloscope with the driven channel always on the





**Figure 5-4**  
**Combined Switch Box**  
**Delta Part Number D61-107**

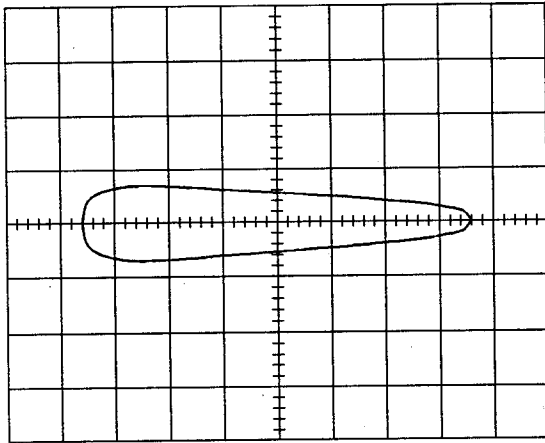
X axis. Thus, the oscilloscope Y axis gain can be increased for fine adjustment of equalization and the SEP controls. When the switch box selection is changed from one setting to another, the fine detail remains available on the Y oscilloscope channel without readjusting the oscilloscope. This switch box is available from Delta and carries Delta part number D61-107.

### 5.5 ADJUSTMENT OF SEPARATION CONTROL

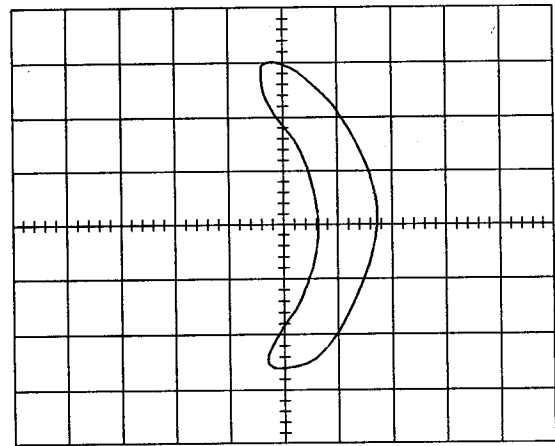
With the test setup as shown in Figure 5-1, set the switch box for left channel only and adjust a 1 kHz audio level so that the L-R meter on the modulation monitor reads 50%. Adjust the SEP control on the front panel for a 50% L+R reading. The oscilloscope figure should approximate a straight horizontal line. At this point, with no equalization or delay adjustments, the oscilloscope display will probably look like a loop similar to Figure 5-5. The SEP control should be adjusted to rotate the loop until the loop's major axis is aligned horizontally. If the loop shows a large amount of curvature, that is, it looks like a banana similar to Figure 5-6, the phasing of the audio to the transmitter is reversed.

### 5.6 DELAY ADJUSTMENT

With the test setup of Figure 5-1 and 50% left channel only audio, adjust the left channel delay switches and 1-8  $\mu$ S trim potentiometer to close the loop. In a similar fashion, set the switch box for right channel only audio and adjust the right channel delay switches and 1-8  $\mu$ S trim potentiometer to close the loop. Note that the resulting line may be slightly tilted from vertical orientation due to IPM in the transmitter.



**Figure 5-5**  
**Correct Audio Phasing**



**Figure 5-6**  
**Incorrect Audio Phasing**

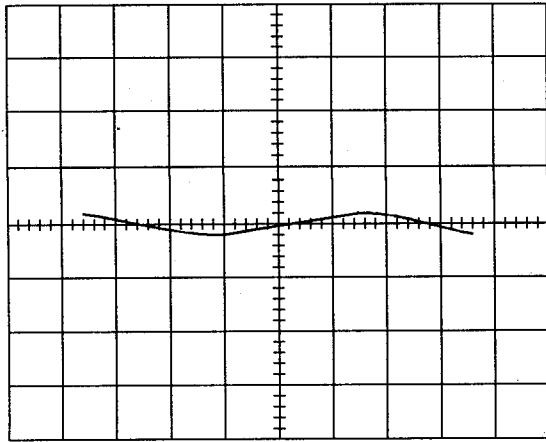
### 5.7 HIGH FREQUENCY EQUALIZATION ADJUSTMENT

For the following adjustments of equalization filters, the ASE-2 should be mounted in the rack and operated at least 30 minutes so that the internal temperature sensor and transconductance amplifiers reach quiescent temperature.

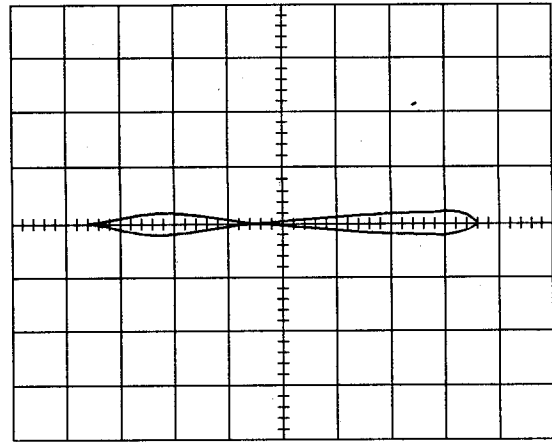
With the test setup of Figure 5-1, set the switch box for 50% left only audio at 5 kHz. With the left equalization switched to the Q path (left most DIP switch) and the CONT control straight up (approximately butterworth response) adjust the HF EQ control to close the loop. Adjust the CONT control, if necessary, to align the loop horizontally. Adjustment of the CONT control has a slight interaction with the HF EQ control so that repeated adjustment of these controls is necessary to produce a closed loop oriented horizontally. Use a similar procedure to adjust the right channel high frequency equalization.

Since the high frequency equalization circuit introduce delay, the delay circuit must be readjusted at 1 kHz. This is an iterative process; the adjustment of the high frequency equalization and adjustment of the delay are repeated until the loop is closed at both 1 kHz and 5 kHz. The SEP control is then adjusted at 1 kHz to best align the left only and right only lines with the horizontal and vertical axes of the oscilloscope display. The SEP control setting is further optimized for the best compromise producing equal left and right channel separation as measured with an RMS detector connected to the modulation monitor.

Due to the presence of distortion or distortion with IPM, the oscilloscope display may appear similar to Figures 5-7 and 5-8. This may represent the best obtainable results given the limitations of transmitter performance.



**Figure 5-7**  
*Single Channel with Distortion*



**Figure 5-8**  
*Single Channel with Distortion and IPM*

## 5.8 LOW FREQUENCY EQUALIZATION ADJUSTMENT

With the test setup of Figure 5-1, set the switch box for left channel only audio at 100 Hz. Adjust the left low frequency equalization control to close the loop of the oscilloscope display. Do the same for right channel only audio. Usually, the low frequency equalization adjustment does not affect the delay and high frequency equalization. However, these adjustments should be re-checked.

## 5.9 AUDIO INPUT BALANCE ADJUSTMENT

Normally, the AUDIO INPUT BALANCE control is adjusted for a null at the AUDIO OUTPUT connector, TB3, with 1 kHz L-R (L=-R). The arrow on the AUDIO INPUT BALANCE control will be approximately straight up. A small pencil mark should be placed on the front panel to indicate the null position of this control.

With some transmitters which cannot be well neutralized, a deliberate misadjustment of the AUDIO INPUT BALANCE control can counter the effects of incidental phase modulation. Thus, slight improvements in separation may be realized. However, misadjustment of the AUDIO INPUT BALANCE control should be a last resort.

## 5.10 DELAY REQUIRED IN I (AUDIO) PATH

Usually, the audio signal proceeds through the transmitter to the modulator more slowly than the RF signal passes through the RF chain. Therefore, the delay circuits are normally in the Q path to delay the RF signal so that the RF and audio signals arrive at the final amplifier (high level modulation) at the same time.

Some transmitters, however, have nearly equal delays through their audio and RF circuits. In this case, additional delay in the I path may be required to close the loop at 5 kHz. The easiest solution to this problem is inserting the high frequency equalization in the I path with the HF EQ control fully counterclockwise. The 1-8  $\mu$ S DELAY control adjusts for a closed loop at 5 kHz.

If this approach is unsatisfactory, the delay circuits may be wired into the I path. This involves removing jumpers W6 through W11 and rewiring so that the delay circuits are installed in W6 and W7. This is most easily seen in Figure 3-1, the block diagram. Use insulated wires to make the following connections:

<u>From</u>	<u>To</u>	<u>From</u>	<u>To</u>
W8-1	W9-2	W10-1	W11-2
W8-2	W7-1	W10-2	W6-1
W9-1	W7-2	W11-1	W6-2

## 5.11 PERFORMANCE EVALUATION

Although stereo separation as low as 14 dB sounds quite pleasing, nearly all transmitters can achieve 20 dB separation in the 100 Hz to 5 kHz range. Thus, 20 dB should be considered minimum acceptable performance. In the mid audio range, separation ranging from 30 dB to 40 dB is good to excellent performance, respectively. Typically, the stereo separation at 5 kHz will be around 5 dB less than the separation at 1 kHz depending on transmitter characteristics. Separation greater than 40 dB is superior performance.

As an aid to performance evaluation, a proof sheet and a semi-log graph are included at the end of this section. You may copy these pages. The proof sheet has areas for recording data from suggested performance tests. This data should be plotted on the semi-log graph so that a visual inspection of the plotted data points will indicate the need for any additional tests.

## 5.12 PILOT OSCILLATOR SELECT

When the equalization and delay circuits are set as described above, the PILOT switch is set to the OUT position. For program modulation, do not forget to turn the PILOT switch on. AM stereo radios cannot decode stereo without the pilot signal.

## 5.13 CLEAR PLASTIC ACCESS COVER

The clear plastic access cover is a lexan (polycarbonate) sheet that fits onto the front panel as a dust cover and prevents inadvertent tampering. The cover attaches to the front panel with two #4-40 screws. Since the lexan has a higher temperature coefficient than the front panel, the mounting screws should be only lightly tightened to prevent bowing of the cover during temperature changes.

## 5.14 OCCUPIED BANDWIDTH AND SPURIOUS OUTPUT COMPLIANCE

Although both the transmitter and the ASE-2 are type accepted and modification of the transmitter for operation with the exciter is permitted, the modified transmitter must be checked to assure compliance with applicable regulations. In the United States, the permissible occupied bandwidth and spurious output level are governed by Federal Communications Commission rule §73.44. Under stereo program modulation and with NRSC preemphasis and filtering active, check the occupied bandwidth with the following spectrum analyzer setup:

### Spectrum Analyzer Control

### Setting

Sweep Time:	10 Minutes
Resolution Bandwidth:	300 Hz
Center Frequency:	Carrier Frequency
Recommended Span:	200 kHz
Video Filter:	Off
Maximum Hold:	On
Reference Level:	Unmodulated Carrier

According to the above cited rule, the spectrum must lie below the following limits:

### Frequency from Carrier

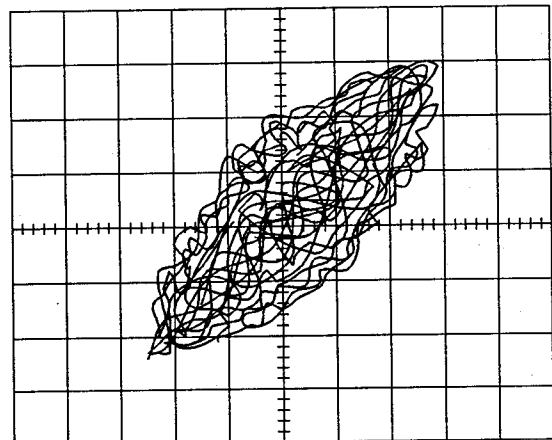
### dB below Reference

10.2 kHz to 20 kHz	25 dB
20 kHz to 30 kHz	35 dB
30 kHz to 60 kHz	5 dB+1 dB/kHz
60 kHz to 75 kHz	65 dB
>75 kHz	80 dB if Power $\geq 5000W$ , 65 dB if Power $\leq 158W$ , 43+10Log (Power) dB if $158W < \text{Power} < 5kW$

The spectrum should be checked for spurious outputs from 37 kHz (the lowest oscillator frequency) to ten times the carrier frequency. Delta recommends that the spectrum measurements be conducted, if possible, with the transmitter operating into a dummy load rather than field measurements one kilometer from the center of the antenna system. This assures compliance to type acceptance standards and avoids the difficulties of interference from other stations associated with field measurements. For reasonable sweep times, increase the resolution bandwidth and employ a carrier frequency notch filter, if necessary.

## 5.15 ADJUSTMENT OF STEREO AUDIO PROCESSING

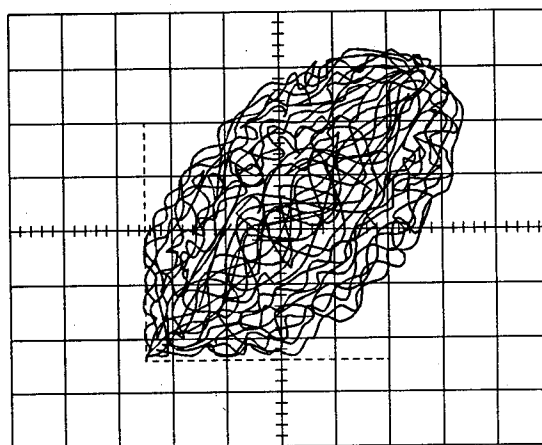
With the oscilloscope connected for X-Y display of the left and right channel outputs of the modulation monitor and with program material, the oscilloscope display should look similar to Figure 5-9. The left channel is the horizontal axis and the right channel is the vertical axis. The main channel or envelope modulation extends from the lower left to the upper right at 45 degrees from horizontal. The lower left hand portion of the modulation is negative envelope. The subchannel audio is displayed from lower right to upper left at 135 degrees from horizontal. Figure 5-9 shows an oval "fuzz ball" with the subchannel level typically below the main channel level. For monophonic operation without pilot, the display would be a much narrower line with the line width determined by incidental phase modulation.



**Figure 5-9**  
**Stereo Program Modulation**

Two monophonic audio processors cannot be used to independently control the left and right channel audio because the envelope modulation, the sum of left and right, is not adequately controlled. An AM stereo audio processor not only controls the envelope but controls the level of each channel so that high phase angle modulation of the RF does not occur. If a significant amount of subchannel exists during negative envelope modulation, high RF phase angles ( $\phi$ ) will result. Since a variable gain amplifier within decoder circuits has a gain of  $1/\cos\phi$ , high phase angles approaching 90 degrees require a gain approaching infinity. In reality, the amplifier runs out of gain and an objectionable clicking sound occurs. To avoid this phenomenon, a single channel limiter circuit exists in AM stereo audio processors. Please refer to your audio processor technical manual for details on adjustment of the single channel limiter. If sufficient subchannel modulation is present, the effect of the single channel limiter circuit will be visible on the oscilloscope display. Figure 5-10 shows the single channel limiter action on the "fuzz ball" limiting the signal to the dashed lines.

Many stereo audio processors have a stereo enhance control that boosts the gain of the subchannel (L-R). With this control turned up, the programming appears to have more separation. However, care should be exercised since too much stereo enhancement will create a "hole" in the center of the stereo image. For example, a single vocalist will appear in the center of the stereo image with the band instruments arrayed from left to right. As the stereo enhance is increased, the band becomes more pronounced at the expense of the vocalist. With extreme amounts of stereo enhance, the vocalist may virtually disappear.



**Figure 5-10**  
**Single Channel Limiting**

None of the controls on the Model ASE-2 should be adjusted for the purpose of increasing or decreasing envelope modulation level. The SEP control does change the level of the audio to the transmitter's modulator but this adjustment is made in relation to the phase modulation to maximize separation. This is why this control is labeled SEP instead of L+R.

To adjust envelope modulation level, adjust the audio processing equipment for the appropriate level to the ASE-2 to attain the desired envelope modulation. Most stereo audio processors require two adjustments to attain the correct level of both left and right channel output. First, an L+R adjustment is set for the desired negative envelope modulation, perhaps an occasional -99% peak. Second, one channel of the audio processor's input is disabled and an L-R control is set for maximum separation. Some audio processors make provision for disabling one channel without actually disconnecting the audio input. Some care should be applied in this process since many audio processors attempt to increase the single channel modulation for a high level of envelope modulation. Adjustment of the L-R control under these conditions may not yield optimal results. If a processor defeat switch is available, try defeating the processing before making the L-R adjustment. Alternately, the program level may be temporarily reduced at the source below the level where the processor can "pump" so that the single channel modulation is moderate. An X-Y oscilloscope display of the left versus right channel outputs of the stereo modulation monitor will be helpful.

## 5.16 SYNCHRONOUS OPERATION

To ensure correct operation of the optional synchronous transmitter circuits, observe the RF LOCK and PILOT LOCK indicators on the front panel. If the internal oscillators are locked to their respective external reference sources, these indicators will be illuminated. The carrier frequency may be verified by connecting a frequency counter to the SYNC OUTPUT connector, J1, on the rear panel. This frequency must be exactly the same as the RF reference frequency supplied to the RF INPUT connector, J4.

Similarly, the pilot signal from the stereo modulation monitor's PILOT TONE connector, J15 of the Model ASM-1, can be compared to the pilot frequency at the ASE-2 PILOT INPUT connector, J5. This is best checked with the program audio temporarily turned off so that any subchannel audio near 25 Hz does not affect the 25 Hz signal from the PILOT TONE connector. A dual channel oscilloscope comparison of the two waveforms may be more convenient.

## 5.17 PATTERN CHANGE

The ASE-2 is designed to operate with one transmitter and, therefore, has only one set of equalization and delay controls. These controls adjust the characteristics of the ASE-2 to compensate for the characteristics of the transmitter for optimum C-QUAM at the transmitter's output. Usually the characteristics of the transmitter are more important than the characteristics of the antenna system (load). If the ASE-2 is adjusted with the transmitter operating into a dummy load, only slight adjustments of the high frequency equalization and delay controls are necessary to operate into the antenna system. This is the case where the antenna system is reasonably broad band.

If the transmitter is operated into varying loads such as day, non-directional and then night, directional patterns, some compromise in stereo performance should be expected. This is due to the generally narrower bandwidth of the directional array. The high frequency equalization and delay controls should then be adjusted for the best possible performance in both patterns. Alternately, the ASE-2 may be set for best stereo performance during the most important listening period.

A properly designed and maintained antenna array should not cause excessive loss in stereo performance with pattern change. If a large loss in stereo performance occurs, then the modulation's sidebands due to higher audio frequencies are not efficiently radiated and the antenna system should be upgraded. This is, of course, just as valid for monophonic operation. If the array cannot be sufficiently broad-banded, a second ASE-2 may be necessary for the alternate pattern.

# AM STEREO INSTALLATION PROOF

## FREQUENCY RESPONSE dB

Frequency Hz → Modulation ↓	50	100	200	400	1k ref.	2k	3k	5k	7.5k	10k
L+R 75%					0					
L-R 100%					0					
L 75%					0					
L 50%					0					
R 75%					0					
R 50%					0					

## DISTORTION PERCENT

Frequency Hz → Modulation ↓	50	100	200	400	1k	2k	3k	5k	7.5k	10k
L+R 75%										
L-R 100%										
L 75%										
L 50%										
R 75%										
R 50%										

## SEPARATION/CROSSTALK dB

Frequency Hz → Modulation ↓	50	100	200	400	1k	2k	3k	5k	7.5k	10k
L+R 75%										
L-R 100%										
L 75%										
L 50%										
R 75%										
R 50%										

Carrier Frequency: \_\_\_\_\_ Carrier Regulation @ 80% L+R 400 Hz: \_\_\_\_\_

Pilot Frequency: \_\_\_\_\_ Pilot Level: \_\_\_\_\_ Date: \_\_\_\_\_

L-R @ 75% 1 kHz Monophonic (IPM): \_\_\_\_\_ Name: \_\_\_\_\_




10K

1K

FREQUENCY, HZ

100

50

## SECTION 6

### MAINTENANCE

#### 6.1 INTRODUCTION

This section describes on-site maintenance procedures and includes an alignment procedure. The Model ASE-2 is a self-contained unit requiring little periodic maintenance. The ASE-2 has been designed using established technology and conservative design practices and should, therefore, operate reliably for many years.

#### 6.2 CLEANING

Avoid using abrasive or chemically harsh cleaning agents. A harsh chemical may react with the polycarbonate overlays or the clear plastic cover (also polycarbonate). Abrasive cleaners can scratch the clear plastic cover and remove the corrosion resistant, iridite finish on the chassis. A mild liquid glass cleaner on a soft, clean cloth is recommended.

#### 6.3 CARRIER OSCILLATOR ADJUSTMENT

The operating frequency of the Model ASE-2 is most easily measured by connecting an accurate frequency counter to the SYNC OUTPUT connector, J1, located on the rear panel of the ASE-2. Check this frequency periodically to assure conformance to applicable government regulations. In the unlikely event that the frequency is not within acceptable limits, remove the top cover of the unit and adjust trimmer capacitor C64 for the correct operating frequency. Note that in synchronous operation, the ASE-2's frequency is determined by an external reference frequency source. If this external source is on frequency and the ASE-2 is not, the RF LOCK detector light will extinguish. In this case, adjust C64 to set the voltage at U7 pin 6 to 6.0 VDC.

#### 6.4 PILOT LEVEL AND FREQUENCY CHECK

Periodically check the pilot level and frequency. Using the Model ASM-1 AM Stereo Modulation Monitor, switch the front panel PILOT /CARRIER switch to the PILOT position for a quick check of the pilot level. If the meter located immediately above this switch reads in the black square, the pilot level is correct. A more careful method for checking pilot level is to remove program audio and check the pilot level on the L-R meter. The meter should read 5% (-26 dB). The pilot frequency is available from the PILOT TONE connector, J6, on the rear panel of the ASM-1. This frequency should be checked in the absence of program audio and should be 25 Hz  $\pm$ 0.02 Hz.

## 6.5 REPAIRS

The Model ASE-2 has been designed to be free of critical adjustments requiring specialized laboratory equipment. The circuit is easy to troubleshoot because all the circuits of the ASE-2's single printed circuit board are readily accessible by removing the top cover. Problems can usually be readily identified using an ordinary oscilloscope. For these reasons, troubleshooting and field repair are relatively straightforward. Consult the theory of operations section of this technical manual, Section 3, as an aid to troubleshooting.

The circuit may be divided into three sections: the audio section, the RF section and the power supply. The power supply is the easiest to repair since, once the defective components are replaced, only a voltage adjustment along with output ripple and stability checks are required. Once the power supply has been repaired, check the remainder of the circuit for proper operation. Sometimes a power supply failure is related to failure in some other circuit.

The audio circuits are mainly operational amplifier circuits and are also relatively easy to repair. Some operational amplifier circuits have offset adjustments that will need adjustment if the operational amplifier is replaced. If an operational transconductance amplifier is replaced, the circuit's gain adjustment will have to be set. In all audio tests and adjustments, temporarily removing U6 will eliminate the low level RF signal visible on an oscilloscope.

In the RF circuit, the most critical circuit is the elliptical low pass filter inside the shielded enclosure. This circuit is carefully designed using only rugged, fixed value, passive components. Therefore, failure of the elliptical low pass filter is highly unlikely. The remainder of the RF chain is easily inspected with an oscilloscope ( $\geq 10$  MHz BW). When viewing the lower RF stages, temporary removal of U6 will eliminate the low level transients associated with limiter U6. The most critical adjustment of the RF chain is the offset adjustment of the limiter, U6. If a modulator is replaced, its offset and gain adjustments must be set.

## 6.6 ALIGNMENT PROCEDURE

The following alignment procedure is included to facilitate accurate adjustment of the Model ASE-2 after repair. Review the entire procedure and verify that necessary equipment is available before attempting any adjustments. Note that certain equipment is only used for testing circuits with the synchronous transmitter option installed and that the spectrum analyzer is used only to test the elliptical filter. Also note that when adjusting the gain of the transconductance amplifier stages, a 4 digit or 4 and 1/2 digit DVM is required for very accurate gain adjustment.

The alignment procedure is organized so that the power supply is adjusted first; the audio sections are adjusted second and the radio frequency circuits are adjusted third. Steps 6.6.2.1 through 6.6.2.16 are power supply tests. Steps 6.6.2.17 through 6.6.2.36 are audio circuit adjustments. Sections 6.6.2.37 through 6.6.2.43 are the alignment steps for the RF circuits.

## 6.6.1 Equipment Required

Table 6-1  
Equipment Required

<u>Description</u>	<u>Note</u>
Digital Multimeter .....	at least 3 and 1/2 digits
Temperature Probe	
Frequency Counter	
Dual Trace Oscilloscope .....	must have alternate A/B triggering and built in 4 digit DVM; Tektronix Model 2236 is recommended
Audio Oscillator .....	must have Low Distortion and a Balanced Output; Tektronix Model SG505 is recommended
Synthesized Function Generator ...	needed for synchronous option test if audio oscillator is not synthesized
Distortion Analyzer .....	Tektronix Model AA501 is recommended
Spectrum Analyzer .....	with tracking generator and high impedance probe
RF Generator .....	low phase noise for synchronous transmitter option test
50 ohm coaxial cables	
50 ohm coaxial termination .....	6.8W High Level Output
Audio Switch Box .....	Recommended, see Section 5.4

## 6.6.2 Electrical Alignment

### 6.6.2.1 Ohmmeter Power Line Check - LINE to NEUTRAL - 10 to 60 $\Omega$

Using the DMM, verify that the resistance between the line (L) and neutral (N) pins on the AC line filter (FL1) is between 10 and 60 ohms.

### 6.6.2.2 Ohmmeter Power Line Check - LINE to GROUND - >20K $\Omega$

Using the DMM, verify that the resistance between the line (L) pin and chassis ground is greater than 20,000 ohms.

### 6.6.2.3 Preset Regulators - R3, R118, R87, (R323) CCW

Set the regulator adjustment trimmers R3, R118 and R87 (and R323 if installed) fully counterclockwise. Remove U6 which will be reinstalled in step 6.6.2.42. Apply AC power to the ASE-2. Verify that the POWER LED is illuminated.

### 6.6.2.4 VR1 +15 VDC Adjustment - DMM CR24 and Set R3

Using the DMM, probe across CR24 cathode (+) and anode (-). Adjust R3 for +15.00  $\pm$ 0.01 VDC.

### 6.6.2.5 VR2 -15 VDC Adjustment - DMM CR4 and Set R87

Using the DMM, probe across CR4 anode (+) and cathode (-). Adjust R87 for -15.00  $\pm$ 0.01 VDC.

#### **6.6.2.6 VR3 +5 VDC Adjustment - DMM CR6 and Set R118**

Using the DMM, probe across CR6 cathode (+) and anode (-). Adjust R118 for  $+5.00 \pm 0.01$  VDC.

#### **6.6.2.7 Optional VR6 +5 VDC Adjustment - DMM CR31 and Set R323**

If VR6 is installed, connect the DMM probes across CR31 cathode (+) and anode (-). Adjust R323 for  $+5.00 \pm 0.01$  VDC.

#### **6.6.2.8 Optional VR4 -15 VDC Check - DMM CR15**

If VR4 is installed, connect the DMM probes across CR15 anode (+) and cathode (-). Verify  $-15.00 \pm 0.50$  VDC.

#### **6.6.2.9 OPTIONAL VR5 +15 VDC Check - DMM CR2**

If VR5 is installed, connect the DMM probes across CR2 cathode (+) and anode (-). Verify  $+15.00 \pm 0.50$  VDC.

#### **6.6.2.10 VR1 Ripple Check - CR24 <25 mV p-p & No Oscillation**

Connect the oscilloscope probe to CR24 cathode and the ground clip to a convenient ground point. Verify less than 25 mV p-p ripple with no sign of oscillation.

#### **6.6.2.11 VR2 Ripple Check - CR4 <25 mV p-p & No Oscillation**

Move the oscilloscope probe to CR4 anode and verify less than 25 mV p-p ripple with no sign of oscillation.

#### **6.6.2.12 VR3 Ripple Check - CR6 <25mVp-p & No Oscillation**

Move the oscilloscope probe to CR6 cathode and verify less than 25 mV p-p ripple with no sign of oscillation.

#### **6.6.2.13 Check $-5.6 \pm 0.50$ VDC - DMM CR10**

Connect the DMM probes across CR10 anode (+) and cathode (-). Verify  $-5.60 \pm 0.50$  VDC.

#### **6.6.2.14 2.49 VDC Reference Adjustment - DMM CR17 and Set R280**

Connect the DMM probes between the left side of R120 and ground terminal TP12. Adjust R280 for 2.49 VDC.

### 6.6.2.15 Ambient Temperature Measurement

Using the temperature probe, measure the temperature of the rear panel of the chassis in degrees celsius. Using the following equation, calculate  $V_{tc}$ :

$$V_{tc} = (T_a - 25) \times 0.0783 + 9.99 \quad (\text{VDC})$$

where  $T_a$  is the temperature of the rear panel in °C.

Note that unit must be in the test environment for at least 30 minutes and operated for at least five minutes for the case and circuit temperatures to stabilize.

### 6.6.2.16 Temperature Compensation Voltage Check - DMM U31-6

Using the DMM, measure the voltage between U31 pin 6 (+) and ground (-) and verify a voltage within  $\pm 0.55$  VDC of  $V_{tc}$  from above.

### 6.6.2.17 Verify Pilot Frequency CMOS Square Wave

If the synchronous transmitter option is not installed, connect the oscilloscope channel 1 probe to the front pin of R102.

If the synchronous transmitter option is install, connect oscilloscope channel 1 probe to the left side of R100 and provides a 1 Vp-p sine wave at 25.00 Hz from the synthesized function generator or synthesized audio oscillator to J6. The PILOT LOCK LED should illuminate within one minute.

Synchronize the oscilloscope on channel 1 and verify a CMOS level square wave at  $24.99 \pm 0.01$  Hz ( $25.00 \pm 0.01$  Hz for synchronous transmitter option).

### 6.6.2.18 25 Hz Bandpass Filter Adjustment - Scope R103 and Set R92

With the channel 1 probe still connected, connect the channel 2 probe of the oscilloscope, DC coupled, to the front side of R103. Adjust R92 so that the positive peak of the sine wave is centered on the logic low portion of the square wave.

### 6.6.2.19 25 Hz Sine Wave Level and Distortion Test

Remove the oscilloscope probes from the circuit. Ground the negative input of the distortion analyzer to TP2 and connect the positive input to S6 pin 4 (left rear pin). Verify a voltage level between 2.00 and 2.20 Vrms with distortion less than 3.00% with W15 in both the 1-2 and 2-3 positions. Place W15 in the 1-2 position.

### 6.6.2.20 Connect Switch Box and Audio Oscillator

If a switch box is available, connect the audio oscillator to the switch box and the switch box to the left and right audio inputs (TB1 and TB2). If a switch box is not available, the appropriate audio signals for the following steps must be applied manually.

Connect the positive and negative inputs of the distortion analyzer to the positive and negative outputs of the audio oscillator so that the distortion analyzer monitors the audio oscillator output level.

#### **6.6.2.21 L-R Matrix Adjustment - Probe U22-7 and Set R138**

Apply left only 1000 Hz audio at 2.45 Vrms. Set W14 to 2-3. Connect the oscilloscope channel 2 probe to W4 and sync the oscilloscope on channel 2. Connect the channel 1 oscilloscope probe, AC coupled, to U22 pin 7. Adjust R138 for a null of the 1000 Hz signal on oscilloscope channel 1.

Set W14 to 1-2.

#### **6.6.2.22 Input Balance Adjustment - Probe U22-7 and Set R241**

Set all front panel switches off. With the oscilloscope probes still connected, apply L+R 1000 Hz audio at 2.45 Vrms. Adjust the AUDIO INPUT BALANCE control, R241, for a null of the 1000 Hz signal on channel 1 of the oscilloscope. Apply L-R 1000 Hz at 2.45 Vrms and set oscilloscope channel 1 to 1 V/div. Verify an oscilloscope DVM (or use the DMM) reading of  $2.45 \pm 0.05$  Vrms.

#### **6.6.2.23 L+R Matrix Adjustment - Probe U22-8 and Set R124**

Connect the oscilloscope channel 2 probe to W4 and sync the oscilloscope on channel 2. Apply L-R 1000 Hz audio at 2.45 Vrms. Connect the channel 1 oscilloscope probe, AC coupled, to U22 pin 8 and adjust R124 for a null of the 1000Hz signal. Apply L+R 1000 Hz at 2.45 Vrms and set oscilloscope channel 1 to 1 V/div. Verify an oscilloscope DVM (or use the DMM) reading of  $2.45 \pm 0.05$  Vrms.

#### **6.6.2.24 L+R DC Offset Adjustment - DMM U23-8 and Set R126**

Remove W1 and W3 and turn off the audio oscillator output. With the DMM set to the 200 mVDC scale, connect the negative DMM lead to U23 pin 10 and the positive DMM lead to U23 pin 8. Adjust R126 for  $0.0 \pm 0.1$  mVDC.

#### **6.6.2.25 L-R DC Offset adjustment - DMM U23-1 and Set R131**

Connect the negative lead of the DMM to U23 pin 3 and the positive DMM lead to U23 pin 1. Adjust R131 for  $0.0 \pm 0.1$  mVDC.

#### **6.6.2.26 Carrier Insertion Adjustment - Probe U23-8 and Set R121**

Install W3 and apply L+R 1000 Hz at 2.45 Vrms. Connect channel 1 oscilloscope probe to U23 pin 8. Set the oscilloscope for 0.5 V/div, DC coupled and ground reference on the center line of the screen. Adjust R121 so that the negative peaks of the audio are right on the center line of the screen.

#### **6.6.2.27 L+R Limiter Test - Probe U23-8**

Install W1. Move the ground reference to the bottom line of the screen with the oscilloscope still set for 0.5 V/div and DC coupled. Increase the audio oscillator level for 3.5 Vrms. Verify that

the sine wave is clipped at between 1.5 and 3.5 minor divisions (assuming 8 major division with 5 minor divisions each) from the bottom of the screen (-95.7% to -89.9% modulation).

#### **6.6.2.28 Pilot Level Check - Probe U23-1**

Turn off the audio oscillator output and set the oscilloscope for 5 mS/div and channel 1 to 50 mV/div. Connect the channel 1 oscilloscope probe to U23 pin 1. Switch on the PILOT switch, S6, and verify a sine wave at 25 Hz and  $0.33 \pm 0.02$  Vp-p. Turn off the PILOT switch.

#### **6.6.2.29 Second L+R Matrix Adjustment - Probe U43-1 and Set R306**

Apply L-R 1000 Hz at 2.45 Vrms. Connect the channel 2 oscilloscope probe to W4 and sync the oscilloscope on channel 2. Connect channel 1 tip to TP1 and ground to TP2. Adjust R306 for a null of the 1000 Hz signal.

#### **6.6.2.30 SEP Control and Audio Output Test**

Apply L+R 1000 Hz at 2.45 Vrms. Connect the channel 1 oscilloscope probe, AC coupled, to U43 pin 7. Using the oscilloscope's channel 1 DVM (or used the DMM), verify that adjusting R326 (SEP) smoothly adjusts the level at U43 pin 7 from  $0 \pm 0.01$  Vrms to  $2.38 \pm 0.1$  Vrms. Set R326 fully clockwise.

Move the oscilloscope probe to TB3 pin 1 and verify a level of  $3.15 \pm 0.13$  Vrms. Move the oscilloscope probe to TB3 pin 3 and verify the same level as seen at TB3 pin 1  $\pm 0.1$  Vrms.

#### **6.6.2.31 Left High Frequency Equalization Test**

Set all front panel switches off. Set the left CONT control (R201) to straight up. Set the left HF EQ control (R200) fully counterclockwise. Apply L+R 1000 Hz at 2.45 Vrms. Connect the channel 1 oscilloscope probe, AC coupled, to W4. Set channel 1 to 0.5 V/div so that four digits appear on the oscilloscope DVM. Adjust the audio oscillator for  $2.450 \pm 0.010$  Vrms on W4. Switch on the left HF EQ switch (S1A). Adjust R187 for the same reading as above.

Remove the oscilloscope probe and connect the distortion analyzer to W4. Set the distortion analyzer to for a dB reference. Set the audio oscillator for 50 kHz. Verify that the attenuation on W4 is less than 3 dB. Set the audio oscillator for 7 kHz. Set the left HF EQ control (R200) fully clockwise. Verify that the attenuation on W4 is greater than 3 dB. Switch off the HF EQ switch (S1A).

#### **6.6.2.32 Left Low Frequency Equalization Test**

Disconnect the distortion analyzer and reconnect the oscilloscope probe to W4. Set the left LF EQ control (R202) fully counterclockwise. Readjust the audio oscillator (if necessary) for  $2.450 \pm 0.010$  Vrms on W4 at 1000 Hz. Note the oscilloscope DVM reading. Switch on the left LF EQ switch (S1C). Adjust R174 for the same oscilloscope DVM reading as above.

Remove the oscilloscope probe and connect the distortion analyzer to W4. Set the distortion analyzer to a dB reference. Set the audio oscillator for 10 Hz. Verify that the attenuation on W4 is less than 3 dB. Set the audio oscillator for 50 Hz. Set the left LF EQ control (R202) fully



clockwise. Verify that the attenuation on W4 is greater than 3 dB. Switch off the left LF EQ switch (S1C).

#### **6.6.2.33 Right High Frequency Equalization Test**

Set the right CONT control (R273) to straight up. Set the right HF EQ control (R272) fully counterclockwise. Apply L+R 1000 Hz at 2.45 Vrms. Connect the channel 1 oscilloscope probe, AC coupled, to W5. Adjust the audio oscillator level for an oscilloscope DVM reading of  $2.450 \pm 0.010$  Vrms on W5. Switch on the right HF EQ switch (S4A). Adjust R259 for the same oscilloscope DVM reading as above.

Remove the oscilloscope probe and connect the distortion analyzer to W5. Set the distortion analyzer to a dB reference. Set the audio oscillator for 50 kHz. Verify that the attenuation on W5 is less than 3 dB. Set the audio oscillator for 7 kHz. Set the right HF EQ control (R272) fully clockwise. Verify that the attenuation on W5 is greater than 3 dB. Switch off the HF EQ switch (S4A).

#### **6.6.2.34 Right Low Frequency Equalization Test**

Disconnect the distortion analyzer and reconnect the oscilloscope probe to W5. Set the right LF EQ control (R301) fully counterclockwise. Readjust the audio oscillator (if necessary) for an oscilloscope DVM reading of  $2.450 \pm 0.010$  Vrms on W5 at 1000 Hz. Switch on the right LF EQ switch (S4C). Adjust R246 for the same oscilloscope DVM reading as above.

Remove the oscilloscope probe and connect the distortion analyzer to W5. Set the distortion analyzer to a dB reference. Set the audio oscillator for 10 Hz. Verify that the attenuation on W5 is less than 3 dB. Set the audio oscillator for 50 Hz. Set the right LF EQ control (R301) fully clockwise. Verify that the attenuation on W5 is greater than 3 dB. Switch off the right LF EQ switch (S4C).

#### **6.6.2.35 Left Delay Test**

Set both oscilloscope channels for 0.5 V/div, 10  $\mu$ S/div, sync on channel 2. Connect the oscilloscope channel 1 probe, AC coupled, to W4. Connect the oscilloscope channel 2 probe, AC coupled, to W9. Apply L+R at 10 Hz and 2.00 Vrms. Adjust R241 (BALANCE) so that the oscilloscope DVM reads  $2.000 \pm 0.002$  Vrms. Adjust the oscilloscope so that both channel 1 and channel 2 are ground referenced to the center horizontal line of the display.

Switch on the left 32  $\mu$ S delay switch, S2A. Verify  $32 \pm 2$   $\mu$ S delay from channel 2 to channel 1. Verify an oscilloscope DVM reading of  $2.000 \pm 0.040$  Vrms. Switch off S2A.

Set the oscilloscope for 5  $\mu$ S/div. Switch on the left 16  $\mu$ S delay switch, S2B. Verify  $16 \pm 1$   $\mu$ S delay from channel 2 to channel 1. Verify  $2.000 \pm 0.040$  Vrms. Switch off S2B.

Set the oscilloscope for 2  $\mu$ S/div. Switch on the left 8  $\mu$ S delay switch, S2C. Verify  $8 \pm 0.5$   $\mu$ S delay from channel 2 to channel 1. Verify  $2.000 \pm 0.040$  Vrms. Switch off S2C.

Switch on the left variable delay switch, S2D. Verify that the 1-8  $\mu$ S delay control, R224, adjusts the delay from less than 1.5  $\mu$ S to more than 7.5  $\mu$ S with the level staying at  $2.000 \pm 0.040$  Vrms.

Switch on S2A, S2B, S2C and S2D. With R224 fully clockwise, verify  $2.000 \pm 0.1$  Vrms. Switch off S2A, S2B, S2C and S2D.

#### 6.6.2.36 Right Delay Test

Set both oscilloscope channels for 0.5 V/div, 10  $\mu$ S/div, sync on channel 2. Connect oscilloscope channel 1 probe to W5. Connect oscilloscope channel 2 probe to W11. Apply L+R at 10 Hz and 2.00 Vrms. Adjust R241 (balance) so that the oscilloscope DVM reads  $2.000 \pm 0.002$  Vrms. Adjust the oscilloscope so that both channel 1 and channel 2 are ground referenced to the center horizontal line of the display.

Switch on the right 32  $\mu$ S delay switch, S5A. Verify  $32 \pm 2$   $\mu$ S delay from channel 2 to channel 1. Verify  $2.000 \pm 0.040$  Vrms. Switch off S5A.

Set the oscilloscope for 5  $\mu$ S/div. Switch on the right 16  $\mu$ S delay switch, S5B. Verify  $16 \pm 1$   $\mu$ S delay from channel 2 to channel 1. Verify  $2.000 \pm 0.040$  Vrms. Switch off S5B.

Set the oscilloscope for 2  $\mu$ S/div. Switch on the right 8  $\mu$ S delay switch, S5C. Verify  $8 \pm 0.5$   $\mu$ S delay from channel 2 to channel 1. Verify  $2.000 \pm 0.040$  Vrms. Switch off S5C.

Switch on the right variable delay switch, S5D. Verify that the 1-8  $\mu$ S delay control, R302, adjusts the delay from less than 1.5  $\mu$ S to more than 7.5  $\mu$ S with the level staying at  $2.000 \pm 0.040$  Vrms.

Switch on S5A, S5B, S5C and S5D. With R302 fully clockwise, verify  $2.000 \pm 0.1$  Vrms. Switch off S5A, S5B, S5C and S5D.

#### 6.6.2.37 SYNC OUTPUT Level Check

Connect a 50 ohm coaxial cable from the SYNC OUTPUT connector, J1, to the 50 ohm coaxial termination at the oscilloscope input. Verify a carrier frequency square wave at 80 mVp-p to 110 mVp-p.

#### 6.6.2.38 Crystal Frequency Set - Adjust C64

Move the 50 ohm terminator to the frequency counter. If the synchronous transmitter option is not installed, adjust C64 for carrier frequency  $\pm 1$  Hz.

If the synchronous transmitter option is installed, provide a 300 mV sine wave from the RF generator at the carrier frequency to J4 and probe U7 pin 6 using the DMM. Adjust C64 for +6.0 VDC. Verify that the output frequency as measured by the counter tracks the input frequency of the RF generator over  $F_c - 10$  Hz to  $F_c + 10$  Hz and that the RF LOCK indicator stays illuminated.

#### 6.6.2.39 Elliptical Filter Test

Turn off the audio and remove AC power from the ASE-2. Remove U21 (with U6 still out) and connect the spectrum analyzer tracking generator to U21 socket pin 3. Power up the ASE-2 and disconnect the SYNC output. Set the spectrum analyzer for 500 kHz/div, 10 dB/div, 1 kHz resolution bandwidth, video average. Turn on the spectrum analyzer's tracking generator. Connect the

spectrum analyzer's high impedance probe to TP5. Adjust the spectrum analyzer so that the filter passband is aligned with the top line.

Verify that the filter rejection is at least 60 dB for frequencies above the frequency listed in Table 6-2.

Table 6-2  
Filter Stopband

<u>Band</u>	<u>Frequency</u>
1	1491 kHz
2	1791 kHz
3	2211 kHz
4	2841 kHz
5	3741 kHz

Set the spectrum analyzer for 2 dB/div. Verify that the pass band ripple is less than 0.4 dB from F1 to F2 of Table 6-3:

Table 6-3  
Filter Passband

<u>Band</u>	<u>F1</u>	<u>F2</u>
1	530 kHz	621 kHz
2	630 kHz	765 kHz
3	770 kHz	972 kHz
4	980 kHz	1278 kHz
5	1280 kHz	1710 kHz

#### 6.6.2.40 Modulator Adjustment

##### a) I and Q Modulator Balance:

Power down the ASE-2. Install U21. Remove W1 and W3. Connect the oscilloscope channel 1 probe to TP5. Turn off the audio oscillator output. Apply power to the ASE-2 and adjust R146 and R149 for an RF null.

##### b) Set AUDIO INPUT BALANCE:

Apply L+R 1000 Hz at 2.45 Vrms. Probe U23 pin 1 and adjust R241 (BALANCE) for a null of the 1000 Hz signal.

##### c) Carrier Level Check:

Turn off the audio oscillator output. Install W3. With the oscilloscope probe still connected to TP5, verify an RF signal at carrier frequency of 1.3 to 1.8 Vp-p. Remove W3.

d) **Set Q Modulator Gain:**

Apply L+R 1000 Hz at 2.45 Vrms. Connect the oscilloscope channel 2 probe to W4 and sync the oscilloscope on channel 2. With the oscilloscope channel 1 probe still connected to TP5 and channel 1 set to 50 mV/div, adjust the oscilloscope channel 1 position control so that the positive peaks of the suppressed carrier waveform envelope are 3 divisions above the center line. Apply L-R audio at the same frequency and level and adjust R148 so that the positive peaks of the AM waveform are 3 divisions above the center line.

e) **100% Modulation Check:**

Install W3. Apply L+R 1000 Hz at 2.45 Vrms. Verify a 100% modulated AM waveform (slightly adjust the level of the audio oscillator if necessary).

f) **I and Q Modulator Distortion Test:**

Connect the spectrum analyzer's high impedance probe to TP5. Set the spectrum analyzer for 500 Hz/div centered on the carrier frequency and 10 dB/div. Apply L+R 1000 Hz at 2.45 Vrms. Verify that the second audio harmonic sidebands are at least 56 dB below the carrier level. Apply L-R 1000 Hz at 2.45 Vrms. Verify that the second audio harmonic sidebands are at least 66 dB below the carrier level.

#### **6.6.2.41 Carrier Harmonic Level Test**

Turn off the audio oscillator. Set the spectrum analyzer for 500 kHz per division. Verify that from 0 to 5 MHz the carrier harmonics are all at least 60 dB below the carrier level. Verify that no spurious output exists.

#### **6.6.2.42 TTL Check and RF Limiter Adjustment**

Remove AC power from the ASE-2. Install U6 and restore power. Connect the oscilloscope channel 1 probe to U6 pin 4. Verify a TTL level square wave at carrier frequency. Move the oscilloscope probe to TP7 and verify a TTL level square wave at carrier frequency.

Connect the 50 ohm through load to the oscilloscope channel 2 input and connect a coaxial cable between the TTL OUTPUT (J2) and the 50 ohm through load. Sync the oscilloscope on channel 2 and observe a TTL level square wave on oscilloscope channel 2. Verify that this square wave duty cycle is 45-55%.

Move the coaxial cable from the TTL OUTPUT (J2) to the SYNC OUTPUT (J1) and sync the oscilloscope on channel 2. Apply L+R 1000 Hz at 1.84 Vrms (75% modulation). Set the oscilloscope in the alternate A & B display with 10X horizontal expansion so that both the rising and falling edges of the square wave from TP7 are displayed. Adjust R51 and R149 to minimize the phase modulation on the rising edge and falling edge of the square wave. The phase modulation on each edge must be 4 nS or less.

Install W1.

#### **6.6.2.43 Optional High Level Output Check**

If the High Level Output option is installed, connect the HIGH LEVEL OUTPUT, J3, through a coaxial cable to the 50 ohm through load on the oscilloscope channel 1 input. Set the oscilloscope to 5V/div and verify that the RF LEVEL control adjusts the square wave output continuously from below 5 Vp-p to at least 35 Vp-p.

At full output, place the channel 2 oscilloscope probe to the banded side of CR33 and set the oscilloscope for AC coupled at 50 mV/div. Verify that regulator VR7 is not oscillating.

#### **6.6.2.44 System Test**

This concludes the alignment procedure. Install the ASE-2 following the instructions of Section 4 and make the adjustments of Section 5 for best stereo performance.

## SECTION 7

### LIST OF MATERIAL

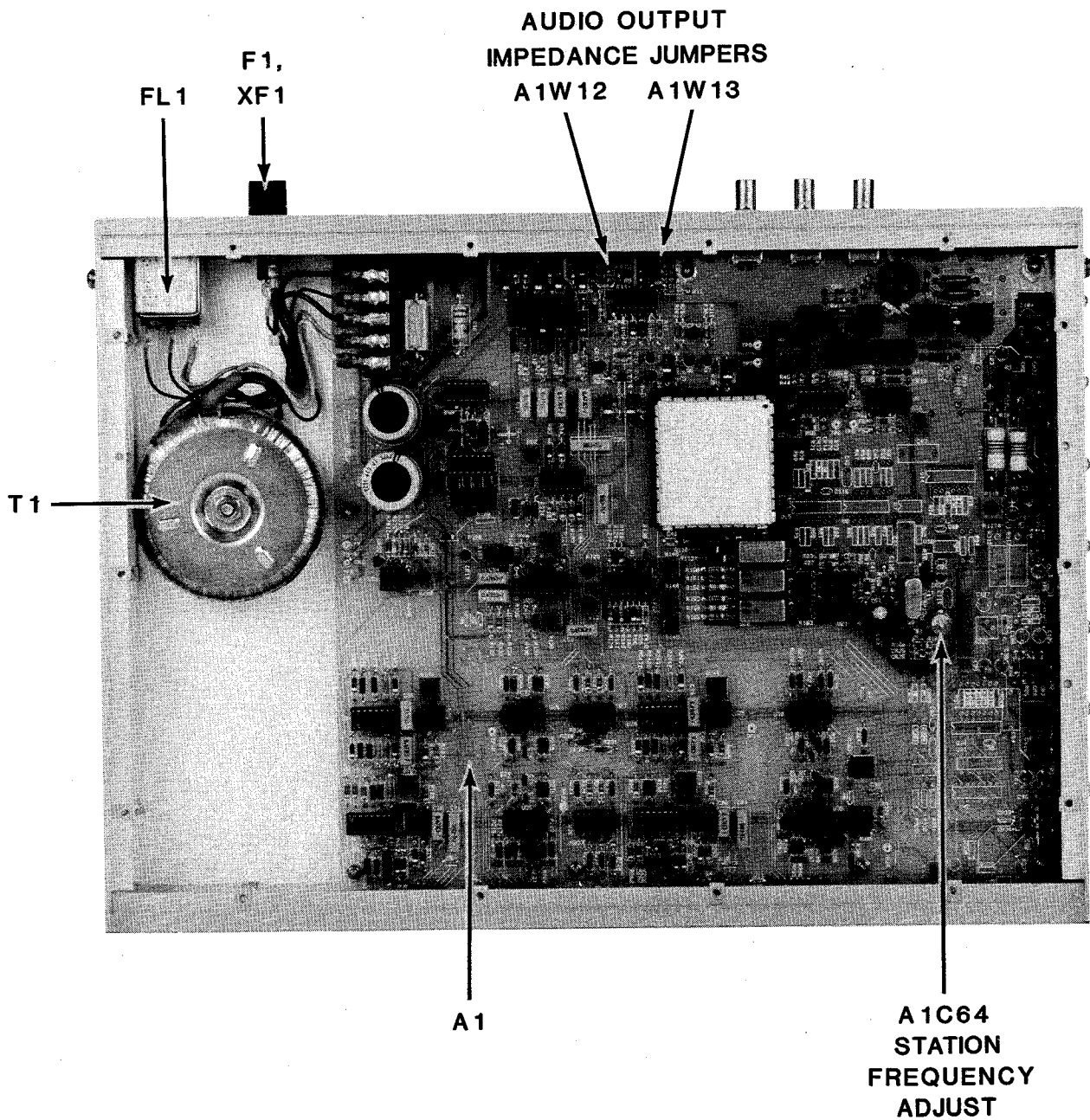
#### 7.1 INTRODUCTION

Maintenance parts in the ASE-2 are identified by reference designations. These designations are used on the photographs, schematic diagrams, and lists of material to identify the components. The component reference designation is also marked adjacent to the component on the printed circuit assembly. The letter(s) in the reference designation identifies the class of item such as a resistor, integrated circuit, or transistor. The number differentiates between parts of subassemblies of the same class.

#### ASE-2 AM STEREO EXCITER LISTS OF MATERIAL

##### TABLE OF CONTENTS

<u>Title</u>	<u>Section</u>	<u>Page</u>
ASE-2 System Components	7.2	7-3
Final Assembly, ASE-2 AM Stereo Exciter	7.3	7-4
Assembly, Exciter	7.4	7-5



*Figure 7-1*  
*Component Locations, Top View*

SECTION 7.2: ASE-2 SYSTEM LIST OF MATERIAL

REF DES	DESCRIPTION	MFR	MFR P/N	DELTA NO.
Unit 1	ASE-2:			
	120/240 VAC Operation:			
	Standard	Delta	D15-20-1	915-0020-001
	High Level Output	Delta	D15-20-2	915-0020-002
	Synchronous Operation	Delta	D15-20-3	915-0020-003
	High Level Output & Synchronous Operation	Delta	D15-20-4	915-0020-004
	100/200 VAC Operation:			
	Standard	Delta	D15-20-5	915-0020-005
	High Level Output	Delta	D15-20-6	915-0020-006
	Synchronous Operation	Delta	D15-20-7	915-0020-007
	High Level Output & Synchronous Operation	Delta	D15-20-8	915-0020-008
W1	Cord, Line, IEC	Belden	17742	678-0035
XTB1	Connector	Weidmuller	12592.6	616-0081
XTB2	Same as XTB1			
XTB3	Same as XTB1			
--	Technical Manual	Delta	D93-443	093-443



SECTION 7.3: ASE-2 FINAL ASSEMBLY LIST OF MATERIAL

REF DES	DESCRIPTION	MFR	MFR P/N	DELTA NO.	NOTES
A1	P.W.B. Assy, Exciter:				
	Standard	Delta	D33-428-1	033-0428-001	See Note 1
	High Level Output	Delta	D33-428-2	033-0428-002	See Note 2
	Synchronous Operation	Delta	D33-428-3	033-0428-003	See Note 3
	High Level Output & Synchronous Operation	Delta	D33-428-4	033-0428-004	See Note 4
F1	Fuse, 3AG, 0.5A Slo-Blo	Littelfuse	313.500	632-1015	100/120 VAC
F1	Fuse, 3AG, 0.25A Slo-Blo	Littelfuse	313.250	632-1011	200/240 VAC
FL1	Filter, Line, IEC	Corcom	3EF1	630-0011	
T1	Transformer, Power, Toroidal	Avel	D4013	362-0047	120/240 VAC
T1	Transformer, Power, Toroidal	Avel	D4014	362-0049	100/200 VAC
XF1	Fuseholder, 3AG	Littelfuse	342014AL	634-0010	

NOTES:

1. Exciter Assembly, part number D33-428-1, used in standard unit, part number D15-20-1 or D15-20-5.
2. Exciter Assembly, part number D33-428-2, used in high level output unit, part number D15-20-2 or D15-20-6.
3. Exciter Assembly, part number D33-428-3, used in synchronous operation unit, part number D15-20-3 or D15-20-7.
4. Exciter Assembly, part number D33-428-4, used in high level output and synchronous operation unit, part number D15-20-4 or D14-20-8.

## SECTION 7.4: ASE-2 AM STEREO EXCITER ASSEMBLY LIST OF MATERIAL, REF DES PREFIX A1

REF DES	DESCRIPTION	MFR	MFR P/N	DELTA NO.	USED ON:
C1	Cap, Fxd, Tant, 10uF, 10%, 50V	Sprague	196D106X9050PE4	326-0027	-1 -2 -3 -4
C2	Cap, Fxd, Tant, 1uF, 10%, 35V	Sprague	196D105X9035HA1	326-0023	-1 -2 -3 -4
C3	Cap, Fxd, Mica, 680pF, 5%		DM15-681J	302-0681	-1 -2 -3 -4
C4	Same as C3				-1 -2 -3 -4
C5	Same as C3				-1 -2 -3 -4
C6	Same as C3				-1 -2 -3 -4
C7	Cap, Fxd, Mica, 150pF, 5%, 500V		CM05FD151J03	302-0151	-1 -2 -3 -4
C8	Same as C7				-1 -2 -3 -4
C9	Same as C7				-1 -2 -3 -4
C10	Same as C7				-1 -2 -3 -4
C11	Cap, Fxd, Mon Cer, 0.47uF, 20%, 50V	Sprague	1C20Z5U474M050B	310-0052	-1 -2 -3 -4
C12	Same as C11				-1 -2 -3 -4
C13	Cap, Fxd, Mon Cer, 0.1uF, 20%, 50V	Sprague	1C10Z5U104M050B	310-0050	-1 -2 -3 -4
C14	Same as C13				-1 -2 -3 -4
C15	Cap, Fxd, Poly, 0.47uF, 63V	REI	MKT1822447065	330-0003	-1 -2 -3 -4
C16	Same as C15				-1 -2 -3 -4
C17	Same as C15				-1 -2 -3 -4
C18	Same as C15				-1 -2 -3 -4
C19	Same as C11				-2 -4
C20	Same as C11				-2 -4
C21	Cap, Fxd, Poly, 2.2uF, 10%, 100V	Nichicon	QYA2A222K	330-0013	-2 -4
C22	Same as C21				-2 -4
C23	Same as C11				-1 -2 -3 -4
C24	Same as C11				-1 -2 -3 -4
C25	Same as C13				-1 -2 -3 -4
C26	Same as C13				-1 -2 -3 -4
C27	Same as C13				-1 -2 -3 -4
C28	Cap, Fxd, Elect, 2700uF, 35V	Sprague	80D272P035JA5	320-0090	-1 -2 -3 -4
C29	Same as C1				-1 -2 -3 -4
C30	Same as C2				-1 -2 -3 -4
C31	Cap, Fxd, Elect, 1800uF, 35V	Sprague	80D182P035HA5	320-0089	-1 -2 -3 -4
C32	Same as C7				-1 -2 -3 -4
C33	Cap, Fxd, Mica, 20pF, 5%, 500V		CM05ED200J03	302-0200	-1 -2 -3 -4
C34	Cap, Fxd, Mica, 10pF, 5%, 500V		CM05CD100J03	302-0100	-1 -2 -3 -4
C35	Cap, Fxd, Poly, 1uF, 63V	REI	MKT1822510065	330-0005	-1 -2 -3 -4
C36	Cap, Fxd, Mica, Selected		See Table 7.1		-1 -2 -3 -4
C37	Cap, Fxd, Mica, Selected		See Table 7.1		-1 -2 -3 -4
C38	Cap, Fxd, Mica, Selected		See Table 7.1		-1 -2 -3 -4
C39	Cap, Fxd, Mica, Selected		See Table 7.1		-1 -2 -3 -4
C40	Same as C11				-1 -2 -3 -4
C41	Same as C11				-1 -2 -3 -4
C42	Same as C11				-1 -2 -3 -4
C43	Cap, Fxd, Poly, 1uF, 63V	REI	MKT1822510065	330-0005	-3 -4
C44	Same as C43				-3 -4
C45	Cap, Fxd, Poly, 1uF, 10%, 100V	Nichicon	QYA2A102K	330-0012	-3 -4
C46	Cap, Fxd, Poly, 10uF, 10%, 100V	Nichicon	QYA2A103K	330-0015	-3 -4
C47	Same as C45				-3 -4
C48	Cap, Fxd, Poly, 0.1uF, 10%, 100V	Nichicon	QYA2A104K	330-0021	-3 -4
C49	Cap, Fxd, Poly, 3.3uF, 10%, 100V	Nichicon	QYA2A332K	330-0014	-3 -4
C50	Cap, Fxd, Mica, 100pF, 5%, 50V		CM05FD101J03	302-0101	-3 -4
C51	Same as C2				-1 -2 -3 -4
C52	Same as C2				-1 -2 -3 -4
C53	Same as C1				-1 -2 -3 -4
C54	Same as C15				-1 -2 -3 -4
C55	Same as C15				-1 -2 -3 -4
C56	Same as C15				-1 -2 -3 -4
C57	Cap, Fxd, Elect, 100uF, 20%, 25V	Nichicon	ULB1E101M	320-0067	-1 -2 -3 -4
C58	Same as C11				-1 -2 -3 -4
C59	Cap, Fxd, Mica, 180pF, 5%, 500V		CM05FD181J03	302-0181	-1 -2 -3 -4
C60	Cap, Fxd, Mica, 24pF, 5%, 500V		CM05ED240J03	302-0240	-1 -2 -3 -4
C61	Same as C59				-1 -2 -3 -4
C62	Cap, Fxd, Mica, 1000pF, 5%		DM15-102J	302-0102	-1 -2 -3 -4
C63	Cap, Fxd, Mica, 33pF, 5%, 500V		CM05ED330J03	302-0330	-1 -2

## SECTION 7.4: ASE-2 AM STEREO EXCITER ASSEMBLY LIST OF MATERIAL, REF DES PREFIX A1

REF DES	DESCRIPTION	MFR	MFR P/N	DELTA NO.	USED ON:
C63	Cap, Fxd, Mica, 10pF, %5		CM05CD100J03	302-0100	-3 -4
C64	Cap, Var, Ceramic, 5.5-18pF	Erie	DV11PS18A	346-0007	-1 -2 -3 -4
C65	Same as C45				-3 -4
C66	Same as C15				-1 -2 -3 -4
C67	Same as C15				-1 -2 -3 -4
C68	Cap, Fxd, Mica, 620pF, 5%		DM15-621J	302-0621	-1 -2 -3 -4
C69	Cap, Fxd, Mica, 200pF, 5%, 500V		CM05FD201J03	302-0201	-1 -2 -3 -4
C70	Same as C15				-1 -2 -3 -4
C71	Same as C35				-1 -2 -3 -4
C72	Same as C62				-1 -2 -3 -4
C73	Same as C62				-1 -2 -3 -4
C74	Same as C62				-1 -2 -3 -4
C75	Same as C62				-1 -2 -3 -4
C76	Same as C62				-1 -2 -3 -4
C77	Same as C62				-1 -2 -3 -4
C78	Cap, Fxd, Mica, 360pF, 5%, 500V		CM05FD361J03	302-0361	-1 -2 -3 -4
C79	Same as C15				-1 -2 -3 -4
C80	Same as C15				-1 -2 -3 -4
C81	Same as C69				-1 -2 -3 -4
C82	Same as C15				-1 -2 -3 -4
C83	Same as C68				-1 -2 -3 -4
C84	Same as C35				-1 -2 -3 -4
C85	Same as C62				-1 -2 -3 -4
C86	Same as C62				-1 -2 -3 -4
C87	Same as C62				-1 -2 -3 -4
C88	Same as C62				-1 -2 -3 -4
C89	Same as C78				-1 -2 -3 -4
C90	Same as C62				-1 -2 -3 -4
C91	Same as C35				-1 -2 -3 -4
C92	Cap, Fxd, Poly, 2.2uF, 10%, 100V	Nichicon	QYA2A222K	330-0013	-3 -4
C93	Same as C50				-3 -4
C94	Same as C43				-3 -4
C95	Same as C46				-3 -4
C96	Cap, Fxd, Tant, 10uF, 10%, 50V		196D106X9050PE4	326-0027	-2 -4
C97	Same as C11				-2 -4
C98	Same as C11				-2 -4
C99	Same as C11				-1 -2 -3 -4
C100	Same as C43				-3 -4
C101	Cap, Fxd, Tant, 1uF, 10%, 35V	Sprague	196D105X9035HA1	326-0023	-2 -4
C102	Same as C101				-2 -4
C103	Same as C101				-2 -4
C104	Same as C101				-2 -4
C105	Same as C101				-3 -4
C106	Same as C105				-3 -4
C107	Cap, Fxd, Tant, 10uF, 10%, 50V	Sprague	196D106X9050PE4	326-0027	-3 -4
C108	Same as C13				-1 -2 -3 -4
C109	Same as C13				-1 -2 -3 -4
C110	Same as C13				-1 -2 -3 -4
C111	Same as C13				-1 -2 -3 -4
C112	Same as C2				-1 -2 -3 -4
C113	Same as C2				-1 -2 -3 -4
C115	Same as C50				-3 -4
C116	Cap, Fxd, Poly, 0.1uF, 10%	Nichicon	QYA2A103K	330-0015	-3 -4
C117	Cap, Fxd, Mon Cer, 0.1uF, 20%, 50V	Sprague	1C10Z5U104M050B	310-0050	-1 -2 -3 -4
C120	Cap, Fxd, Mica, Selected		See Table 7.1		-1 -2 -3 -4
C121	Cap, Fxd, Mica, Selected		See Table 7.1		-1 -2 -3 -4
CR1	Diode, Silicon, 100PIV, 1A		1N4002	410-4002	-1 -2 -3 -4
CR2	Same as CR1				-2 -4
CR3	Same as CR1				-1 -2 -3 -4
CR4	Same as CR1				-1 -2 -3 -4
CR5	Rectifier, Bridge, 100 PIV, 4A	Motorola	MDA970A2	418-0007	-1 -2 -3 -4
CR6	Same as CR1				-1 -2 -3 -4
CR7	Same as CR1				-1 -2 -3 -4

## SECTION 7.4: ASE-2 AM STEREO EXCITER ASSEMBLY LIST OF MATERIAL, REF DES PREFIX A1

REF DES	DESCRIPTION	MFR	MFR P/N	DELTA NO.	USED ON:
CR8	Diode, Zener, 62V, 5%, 1W		1N4759A	410-4759-001	-2 -4
CR9	Same as CR8				-2 -4
CR10	Diode, Zener, 5.6V, 5%, 0.4W		1N752	410-0752-001	-1 -2 -3 -4
CR11	Diode, Light Emitting	Dialco	521-9165	646-0004	-1 -2 -3 -4
CR12	Same as CR11				-1 -2 -3 -4
CR13	Diode, Silicon, Signal, 75PIV		1N4148	410-4148	-3 -4
CR14	Same as CR13				-3 -4
CR15	Same as CR1				-2 -4
CR16	Same as CR1				-2 -4
CR17	Diode, Voltage Reference, 2.5V	National	LM336Z-2.5	548-0033	-1 -2 -3 -4
CR18	Same as CR13				-1 -2 -3 -4
CR22	Same as CR13				-1 -2 -3 -4
CR23	Same as CR1				-2 -4
CR24	Same as CR1				-1 -2 -3 -4
CR25	Same as CR13				-1 -2 -3 -4
CR26	Same as CR13				-1 -2 -3 -4
CR27	Diode, Tuning	Motorola	MV209	416-0018	-3 -4
CR28	Same as CR13				-3 -4
CR29	Same as CR13				-3 -4
CR30	Same as CR1				-3 -4
CR31	Same as CR30				-3 -4
CR32	Diode, Temperature Sensing	National	LM335Z	548-0038	-1 -2 -3 -4
CR33	Same as CR1				-2 -4
CR34	Same as CR1				-2 -4
CR35	Dual Light Emitting Diode, Green, PC Mount	Dialight	552-0122	646-0012	-3 -4
CR36	Diode, Light Emitting, Green, PC Mount	Dialight	550-2206	646-0013	-1 -2 -3 -4
CR37	Same as CR13				-1 -2 -3 -4
CR38	Same as CR13				-1 -2 -3 -4
J1	Connector, BNC, PC Mount	Amp	227677-1	612-0066	-1 -2 -3 -4
J2	Same as J1				-1 -2 -3 -4
J3	Same as J1				-2 -4
J4	Same as J1				-3 -4
J5	Same as J1				-3 -4
J6	Block, Terminal, PC Mount	Augat/RDI	JC6-P102-05	670-0022-005	-1 -2 -3 -4
L1	Inductor, Fxd, 6.8mH	Miller	9250-685	350-0049	-1 -2 -3 -4
L2	Same as L1				-1 -2 -3 -4
L3	Same as L1				-1 -2 -3 -4
L4	Same as L1				-1 -2 -3 -4
L5	Inductor, Fxd, 4.7mH	Miller	9250-475	350-0033	-1 -2 -3 -4
L6	Same as L5				-1 -2 -3 -4
L7	Same as L5				-1 -2 -3 -4
L8	Same as L5				-1 -2 -3 -4
L9	Inductor, Fxd, 33 uH	Miller	74F335A1	350-0028	-2 -4
L10	Same as L9				-2 -4
L11	Inductor, Fxd, Toroidal, 43.0uH	Delta	D63-70-1	063-0070-001	-1 -2 -3 -4
L12	Inductor, Fxd, Toroidal, 49uH	Delta	D63-70-2	063-0070-002	-1 -2 -3 -4
L13	Inductor, Fxd, Toroidal, 4.7uH	Delta	D63-70-3	063-0070-003	-1 -2 -3 -4
L14	Inductor, Fxd, Toroidal, 25.9uH	Delta	D63-70-4	063-0070-004	-1 -2 -3 -4
L15	Inductor, Fxd, Toroidal, 2.7uH	Delta	D63-70-5	063-0070-005	-1 -2 -3 -4
L16	Inductor, Fxd, 220uH	Miller	9250-224	350-0032	-1 -2 -3 -4
L17	Inductor, Fxd, 33uH	Miller	70F335A1	350-0020	-1 -2 -3 -4
Q1	Transistor, MOSFET, Power	Siliconix	VN88AFD	436-0005	-2 -4
Q2	Same as Q1				-2 -4
Q3	Transistor, PNP		2N3906	420-3906	-1 -2 -3 -4
Q4	Transistor, NPN		2N3904	420-3904	-1 -2 -3 -4
Q5	Same as Q3				-1 -2 -3 -4
Q6	Same as Q4				-1 -2 -3 -4
Q7	Same as Q3				-1 -2 -3 -4
Q8	Transistor, JFET		2N5484	420-5484	-1 -2 -3 -4
Q9	Transistor, PNP		2N3906	420-3906	-3 -4
R1	Res, Fxd, 240 ohm, 5%, 1/4W		RL07S241J	202-0241	-1 -2 -3 -4
R2	Res, Fxd, 2.2K, 5%, 1/4W		RL07S222J	202-0222	-1 -2 -3 -4
R3	Res, Var, Trimmer, 1K	Bouras	3386P-1-102	244-0092	-1 -2 -3 -4

## SECTION 7.4: ASE-2 AM STEREO EXCITER ASSEMBLY LIST OF MATERIAL, REF DES PREFIX A1

REF DES	DESCRIPTION	MFR	MFR P/N	DELTA NO.	USED ON:
R4	Res, Fxd, 330 ohm, 5%, 1/4W		RL07S331J	202-0331	-1 -2 -3 -4
R5	Same as R4				-1 -2 -3 -4
R6	Same as R4				-1 -2 -3 -4
R7	Same as R4				-1 -2 -3 -4
R8	Res, Fxd, 360K, 5%, 1/4W		RL07S364J	202-0364	-1 -2 -3 -4
R9	Res, Fxd, 680K, 5%, 1/4W		RL07S684J	202-0684	-1 -2 -3 -4
R10	Same as R9				-1 -2 -3 -4
R11	Same as R8				-1 -2 -3 -4
R12	Res, Fxd, 11.0K, 1%, 1/4W		RN55D1102F	212-1102	-1 -2 -3 -4
R13	Res, Fxd, 20.0K, 1%, 1/4W		RN55D2002F	212-2002	-1 -2 -3 -4
R14	Res, Fxd, 10K, 5%, 1/4W		RL07S103J	202-0103	-1 -2 -3 -4
R15	Res, Fxd, 30K, 5%, 1/4W		RL07S303J	202-0303	-1 -2 -3 -4
R16	Same as R13				-1 -2 -3 -4
R17	Res, Fxd, 30.1K, 1%, 1/4W		RN55D3012F	212-3012	-1 -2 -3 -4
R18	Res, Fxd, 3.3K, 5%, 1/4W		RL07S332J	202-0332	-1 -2 -3 -4
R19	Same as R18				-1 -2 -3 -4
R20	Same as R18				-1 -2 -3 -4
R21	Same as R18				-1 -2 -3 -4
R22	Res, Fxd, 220 ohm, 5%, 1/4W		RL07S221J	202-0221	-1 -2 -3 -4
R23	Res, Fxd, 56 ohms, 5%, 1/4W		RL07S560J	202-0560	-1 -2 -3 -4
R24	Res, Fxd, 1.00K, 1%, 1/4W		RN55D1001F	212-1001	-1 -2 -3 -4
R25	Res, Fxd, 12.1 ohm, 1%, 1/4W		RN55D12R1F	212-0121	-1 -2 -3 -4
R26	Same as R25				-1 -2 -3 -4
R27	Same as R24				-1 -2 -3 -4
R28	Same as R24				-1 -2 -3 -4
R29	Same as R25				-1 -2 -3 -4
R30	Same as R25				-1 -2 -3 -4
R31	Same as R24				-1 -2 -3 -4
R32	Res, Fxd, 270 ohm, 5%, 1/2W		RL20S271J	204-0271	-1 -2 -3 -4
R33	Res, Fxd, 7.50K, 1%, 1/4W		RN55D7501F	212-7501	-1 -2 -3 -4
R34	Same as R32				-1 -2 -3 -4
R35	Same as R33				-1 -2 -3 -4
R36	Same as R32				-1 -2 -3 -4
R37	Same as R33				-1 -2 -3 -4
R38	Same as R32				-1 -2 -3 -4
R39	Same as R33				-1 -2 -3 -4
R40	Res, Fxd, 100K, 5%, 1/4W		RL07S104J	202-0104	-2 -4
R41	Same as R40				-2 -4
R42	Res, Fxd, 330 ohm, 5%, 1/2W		RL20S331J	204-0331	-2 -4
R43	Same as R42				-2 -4
R44	Res, Fxd, 1K, 5%, 1/4W		RL07S102J	202-0102	-1 -2 -3 -4
R45	Res, Fxd, 7.5K, 5%, 1/4W		RL07S752J	202-0752	-1 -2 -3 -4
R46	Same as R44				-1 -2 -3 -4
R47	Res, Fxd, 470 ohm, 5%, 1/4W		RL07S471J	202-0471	-1 -2 -3 -4
R48	Res, Fxd, 160 ohm, 5%, 1/2W		RL20S161J	204-0161	-2 -4
R49	Same as R44				-1 -2 -3 -4
R50	Same as R45				-1 -2 -3 -4
R51	Res, Var, Trimmer, 100K	Bourne	3386P-1-104	244-0098	-1 -2 -3 -4
R52	Same as R44				-1 -2 -3 -4
R53	Res, Fxd, 560K, 5%, 1/4W		RL07S564J	202-0564	-1 -2 -3 -4
R54	Same as R44				-1 -2 -3 -4
R55	Res, Fxd, Selected		See Table 7.1		-1 -2 -3 -4
R56	Res, Fxd, 62K, 5%, 1/4W		RL07S623J	202-0623	-3 -4
R57	Res, Fxd, 47K, 5%, 1/4W		RL07S473J	202-0473	-3 -4
R58	Res, Fxd, 510 ohm, 5%, 1/4W		RL07S511J	202-0511	-3 -4
R59	Same as R58				-3 -4
R60	Same as R57				-3 -4
R61	Res, Fxd, 330K, 5%, 1/4W		RL07S334J	202-0334	-3 -4
R62	Same as R57				-3 -4
R63	Same as R61				-3 -4
R64	Res, Fxd, 56 ohm, 5%, 1/2W		RL20S560J	204-0560	-3 -4
R65	Same as R57				-3 -4
R66	Same as R58				-3 -4

## SECTION 7.4: ASE-2 AM STEREO EXCITER ASSEMBLY LIST OF MATERIAL, REF DES PREFIX A1

REF DES	DESCRIPTION	MFR	MFR P/N	DELTA NO.	USED ON:
R67	Same as R58				-3 -4
R68	Same as R57				-3 -4
R69	Res, Fxd, 220 ohm, 5%, 1/4W		RL07S221J	202-0221	-3 -4
R70	Same as R69				-3 -4
R71	Res, Fxd, 1K, 5%, 1/4W		RL07S102J	202-0102	-3 -4
R72	Same as R71				-3 -4
R73	Same as R71				-3 -4
R74	Same as R69				-3 -4
R75	Res, Fxd, 10K, 5%, 1/4W		RL07S103J	202-0103	-3 -4
R76	Res, Fxd, 270K, 5%, 1/4W		RL07S274J	202-0274	-3 -4
R77	Same as R75				-3 -4
R78	Same as R69				-1 -3 -4
R79	Same as R69				-1 -3 -4
R80	Same as R69				-3 -4
R81	Same as R69				-3 -4
R82	Same as R69				-3 -4
R83	Res, Fxd, 91K, 5%, 1/4W		RL07S913J	202-0913	-3 -4
R84	Res, Fxd, 360 ohm, 5%, 1/4W		RL07S361J	202-0361	-3 -4
R85	Same as R1				-1 -2 -3 -4
R86	Same as R2				-1 -2 -3 -4
R87	Same as R3				-1 -2 -3 -4
R88	Res, Fxd, 1 ohm, 5%, 2W		RL42S1R0J	208-0010	-1 -2 -3 -4
R89	Res, Fxd, 0.68 Ohm, 5W, WW	IRC	PW5-0.68 OHM	224-0072	-1 -2 -3 -4
R90	Same as R14				-1 -2 -3 -4
R91	Res, Fxd, 12M, 5%, 1/4W		RL07S126J	202-0126	-1 -2 -3 -4
R92	Res, Var, Trimmer, 2K	Bourms	3386P-1-202	244-0101	-1 -2 -3 -4
R93	Same as R14				-1 -2 -3 -4
R94	Same as R14				-1 -2 -3 -4
R95	Res, Fxd, 1.3K, 5%, 1/4W		RL07S132J	202-0132	-1 -2 -3 -4
R96	Same as R14				-1 -2 -3 -4
R100	Res, Fxd, 3.9K, 5%, 1/4W		RL07S392J	202-0392	-3 -4
R101	Res, Fxd, 5.6K, 5%, 1/4W		RL07S562J	202-0562	-1 -2 -3 -4
R102	Res, Fxd, 62K, 5%, 1/4W		RL07S623J	202-0623	-1 -2 -3 -4
R103	Same as R103				-1 -2 -3 -4
R104	Res, Fxd, 6.2K, 5%, 1/4W		RL07S622J	202-0622	-1 -2 -3 -4
R111	Res, Fxd, Selected		See Table 7.1		-1 -2 -3 -4
R112	Res, Fxd, 91 ohm, 5%, 1/2W		RL20S910J	204-0910	-1 -2 -3 -4
R113	Same as R112				-1 -2 -3 -4
R114	Res, Fxd, 100 ohm, 5%, 2W (S/N 001-010)		RL42S101J	208-0101	-1 -2 -3 -4
R114	Res, Fxd, 40 ohm, 5%, 5W (S/N 011-UP)	IRC	PW5-40 OHM	224-0074	-1 -2 -3 -4
R115	Same as R114 (S/N 001-010)				-1 -2 -3 -4
r115	Unassigned (S/N 011-UP)				
R116	Same as R1				-1 -2 -3 -4
R117	Res, Fxd, 620 ohm, 5%, 1/4W		RL07S621J	202-0621	-1 -2 -3 -4
R118	Res, Var, Trimmer, 200 ohms	Bourms	3386P-1-201	244-0087	-1 -2 -3 -4
R119	Res, Fxd, 6.8K, 5%, 1/4W		RL07S682J	202-0682	-1 -2 -3 -4
R120	Res, Fxd, 3K, 5%, 1/4W		RL07S302J	202-0302	-1 -2 -3 -4
R121	Same as R3				-1 -2 -3 -4
R122	Res, Fxd, 9.53K, 1%, 1/4W		RN55D9531F	212-9531	-1 -2 -3 -4
R123	Same as R122				-1 -2 -3 -4
R124	Same as R3				-1 -2 -3 -4
R125	Res, Fxd, 4.99K, 1%, 1/4W		RN55D4991F	212-4991	-1 -2 -3 -4
R126	Same as R51				-1 -2 -3 -4
R127	Res, Fxd, 7.5M, 5%, 1/4W		RL07S755J	202-0755	-1 -2 -3 -4
R128	Res, Fxd, 10.0K, 1%, 1/4W		RN55D1002F	212-1002	-1 -2 -3 -4
R129	Same as R44				-1 -2 -3 -4
R130	Same as R128				-1 -2 -3 -4
R131	Same as R51				-1 -2 -3 -4
R132	Res, Fxd, 820K, 5%, 1/4W		RL07S824J	202-0824	-1 -2 -3 -4
R133	Same as R132				-1 -2 -3 -4
R134	Same as R13				-1 -2 -3 -4
R135	Same as R13				-1 -2 -3 -4
R136	Same as R122				-1 -2 -3 -4

SECTION 7.4: ASE-2 AM STEREO EXCITER ASSEMBLY LIST OF MATERIAL, REF DES PREFIX A1

REF DES	DESCRIPTION	MFR	MFR P/N	DELTA NO.	USED ON:
R137	Same as R128				-1 -2 -3 -4
R138	Same as R3				-1 -2 -3 -4
R139	Res, Fxd, 180K, 5%, 1/4W		RL07S184J	202-0184	-1 -2 -3 -4
R140	Same as R127				-1 -2 -3 -4
R141	Same as R128				-1 -2 -3 -4
R142	Same as R128				-1 -2 -3 -4
R146	Res, Var, Trimmer, 50K	Bourns	3386P-1-503	244-0095	-1 -2 -3 -4
R148	Same as R3				-1 -2 -3 -4
R149	Same as R146				-1 -2 -3 -4
R150	Res, Fxd, 470K, 5%, 1/4W		RL07S474J	202-0474	-1 -2 -3 -4
R151	Res, Fxd, 2.7K, 5%, 1/4W		RL07S272J	202-0272	-1 -2 -3 -4
R152	Same as R23				-1 -2 -3 -4
R153	Same as R2				-1 -2 -3 -4
R154	Same as R23				-1 -2 -3 -4
R155	Same as R150				-1 -2 -3 -4
R156	Res, Fxd, 33 ohm, 5%, 1/4W		RL07S330J	202-0330	-1 -2 -3 -4
R157	Res, Fxd, 150 ohm, 5%, 1/4W		RL07S151J	202-0151	-1 -2 -3 -4
R158	Same as R156				-1 -2 -3 -4
R159	Same as R157				-1 -2 -3 -4
R160	Same as R156				-1 -2 -3 -4
R161	Same as R157				-1 -2 -3 -4
R162	Same as R156				-1 -2 -3 -4
R163	Same as R157				-1 -2 -3 -4
R164	Same as R14				-1 -2 -3 -4
R165	Res, Fxd, 39K, 5%, 1/4W		RL07S393J	202-0393	-1 -2 -3 -4
R166	Res, Fxd, 100 ohm, 5%, 1/4W		RL07S101J	202-0101	-1 -2 -3 -4
R167	Same as R44				-1 -2 -3 -4
R168	Res, Fxd, 100K, 5%, 1/4W		RL07S104J	202-0104	-1 -2 -3 -4
R169	Same as R57				-3 -4
R170	Res, Fxd, 200 ohm, 1%, 1/4W		RN55D2000F	212-2000	-1 -2 -3 -4
R171	Same as R170				-1 -2 -3 -4
R172	Res, Fxd, 33.2K, 1%, 1/4W		RN55D3322F	212-3322	-1 -2 -3 -4
R173	Same as R14				-1 -2 -3 -4
R174	Res, Var, Trimmer, 100 ohms	Bourns	3386P-1-101	244-0099	-1 -2 -3 -4
R175	Res, Fxd, 22K, 5%, 1/4W		RL07S223J	202-0223	-1 -2 -3 -4
R176	Same as R175				-1 -2 -3 -4
R177	Same as R170				-1 -2 -3 -4
R178	Same as R170				-1 -2 -3 -4
R179	Same as R172				-1 -2 -3 -4
R180	Same as R172				-1 -2 -3 -4
R181	Same as R14				-1 -2 -3 -4
R182	Res, Fxd, 4.7K, 5%, 1/4W		RL07S472J	202-0472	-1 -2 -3 -4
R183	Same as R132				-1 -2 -3 -4
R184	Res, Fxd, 27K, 5%, 1/4W		RL07S273J	202-0273	-1 -2 -3 -4
R185	Same as R170				-1 -2 -3 -4
R186	Same as R170				-1 -2 -3 -4
R187	Res, Var, Trimmer, 10K	Bourns	3386P-1-103	244-0093	-1 -2 -3 -4
R188	Same as R172				-1 -2 -3 -4
R189	Same as R132				-1 -2 -3 -4
R190	Res, Fxd, 18K, 5%, 1/4W		RL07S183J	202-0183	-1 -2 -3 -4
R191	Same as R190				-1 -2 -3 -4
R192	Same as R172				-1 -2 -3 -4
R193	Same as R172				-1 -2 -3 -4
R194	Same as R170				-1 -2 -3 -4
R195	Same as R170				-1 -2 -3 -4
R196	Res, Fxd, 20K, 5%, 1/4W		RL07S203J	202-0203	-1 -2 -3 -4
R197	Res, Fxd, 5.1K, 5%, 1/4W		RL07S512J	202-0512	-1 -2 -3 -4
R198	Same as R14				-1 -2 -3 -4
R199	Same as R14				-1 -2 -3 -4
R200	Res, Var, Trimmer, 100K	Bourns	3386W-1-104	244-0097	-1 -2 -3 -4
R201	Res, Var, Trimmer, 10K	Bourns	3386W-1-103	244-0096	-1 -2 -3 -4
R202	Same as R200				-1 -2 -3 -4
R203	Same as R128				-1 -2 -3 -4

## SECTION 7.4: ASE-2 AM STEREO EXCITER ASSEMBLY LIST OF MATERIAL, REF DES PREFIX A1

REF DES	DESCRIPTION	MFR	MFR P/N	DELTA NO.	USED ON:
R204	Res, Fxd, 6.81K, 1%, 1/4W		RN55D6811F	212-6811	-1 -2 -3 -4
R205	Same as R128				-1 -2 -3 -4
R206	Same as R128				-1 -2 -3 -4
R207	Res, Fxd, 4.75K, 1%, 1/4W		RN55D4751F	212-4751	-1 -2 -3 -4
R208	Res, Fxd, 8.66K, 1%, 1/4W		RN55D8661F	212-8661	-1 -2 -3 -4
R209	Same as R128				-1 -2 -3 -4
R210	Same as R128				-1 -2 -3 -4
R211	Same as R128				-1 -2 -3 -4
R212	Res, Fxd, 5.36K, 1%, 1/4W		RN55D5361F	212-5361	-1 -2 -3 -4
R213	Res, Fxd, 4.53K, 1%, 1/4W		RN55D4531F	212-4531	-1 -2 -3 -4
R214	Res, Fxd, 3.32K, 1%, 1/4W		RN55D3321F	212-3321	-1 -2 -3 -4
R215	Same as R128				-1 -2 -3 -4
R216	Res, Fxd, 4.02K, 1%, 1/4W		RN55D4021F	212-4021	-1 -2 -3 -4
R217	Same as R128				-1 -2 -3 -4
R218	Same as R128				-1 -2 -3 -4
R219	Same as R128				-1 -2 -3 -4
R220	Same as R216				-1 -2 -3 -4
R221	Same as R128				-1 -2 -3 -4
R222	Same as R128				-1 -2 -3 -4
R223	Res, Fxd, 1.43K, 1%, 1/4W		RN55D1431F	212-1431	-1 -2 -3 -4
R224	Same as R201				-1 -2 -3 -4
R225	Same as R128				-1 -2 -3 -4
R226	Same as R132				-1 -2 -3 -4
R227	Same as R132				-1 -2 -3 -4
R228	Same as R128				-1 -2 -3 -4
R229	Res, Fxd, 619 ohms, 1%, 1/4W		RN55D6190F	212-6190	-1 -2 -3 -4
R230	Res, Fxd, 11.3K, 1%, 1/4W		RN55D1132F	212-1132	-1 -2 -3 -4
R231	Same as R230				-1 -2 -3 -4
R232	Res, Fxd, 3.83K, 1%, 1/4W		RN55D3831F	212-3831	-1 -2 -3 -4
R233	Same as R128				-1 -2 -3 -4
R234	Same as R132				-1 -2 -3 -4
R235	Same as R132				-1 -2 -3 -4
R236	Same as R128				-1 -2 -3 -4
R237	Same as R229				-1 -2 -3 -4
R238	Same as R230				-1 -2 -3 -4
R239	Same as R230				-1 -2 -3 -4
R240	Same as R232				-1 -2 -3 -4
R241	Res, Var, Trimmer, 5K	Bourns	3386W-1-502	244-0100	-1 -2 -3 -4
R242	Same as R170				-1 -2 -3 -4
R243	Same as R170				-1 -2 -3 -4
R244	Same as R172				-1 -2 -3 -4
R245	Same as R14				-1 -2 -3 -4
R246	Same as R174				-1 -2 -3 -4
R247	Same as R175				-1 -2 -3 -4
R248	Same as R175				-1 -2 -3 -4
R249	Same as R170				-1 -2 -3 -4
R250	Same as R170				-1 -2 -3 -4
R251	Same as R172				-1 -2 -3 -4
R252	Same as R172				-1 -2 -3 -4
R253	Same as R14				-1 -2 -3 -4
R254	Same as R182				-1 -2 -3 -4
R255	Same as R132				-1 -2 -3 -4
R256	Same as R184				-1 -2 -3 -4
R257	Same as R170				-1 -2 -3 -4
R258	Same as R170				-1 -2 -3 -4
R259	Same as R187				-1 -2 -3 -4
R260	Same as R132				-1 -2 -3 -4
R261	Same as R172				-1 -2 -3 -4
R262	Same as R190				-1 -2 -3 -4
R263	Same as R190				-1 -2 -3 -4
R264	Same as R172				-1 -2 -3 -4
R265	Same as R172				-1 -2 -3 -4
R266	Same as R170				-1 -2 -3 -4



## SECTION 7.4: ASE-2 AM STEREO EXCITER ASSEMBLY LIST OF MATERIAL, REF DES PREFIX A1

REF DES	DESCRIPTION	MFR	MFR P/N	DELTA NO.	USED ON:
R267	Same as R170				-1 -2 -3 -4
R268	Same as R196				-1 -2 -3 -4
R269	Same as R197				-1 -2 -3 -4
R270	Same as R14				-1 -2 -3 -4
R271	Same as R14				-1 -2 -3 -4
R272	Same as R200				-1 -2 -3 -4
R273	Same as R201				-1 -2 -3 -4
R274	Res, Fxd, 1.50K, 1%, 1/4W		RN55D1501F	212-1501	-1 -2 -3 -4
R275	Res, Fxd, 5.49K, 1%, 1/4W		RN55D5491F	212-5491	-1 -2 -3 -4
R276	Same as R128				-1 -2 -3 -4
R277	Same as R204				-1 -2 -3 -4
R278	Same as R128				-1 -2 -3 -4
R279	Same as R128				-1 -2 -3 -4
R280	Res, Var, Trimmer, 5K	Bourne	3386P-1-502	244-0090	-1 -2 -3 -4
R281	Res, Fxd, 12K, 5%, 1/4W		RL07S123J	202-0123	-1 -2 -3 -4
R282	Res, Fxd, 8.06K, 1%, 1/4W		RN55D8061F	212-8061	-1 -2 -3 -4
R284	Same as R207				-1 -2 -3 -4
R285	Same as R208				-1 -2 -3 -4
R286	Same as R128				-1 -2 -3 -4
R287	Same as R128				-1 -2 -3 -4
R288	Same as R128				-1 -2 -3 -4
R289	Same as R212				-1 -2 -3 -4
R290	Same as R213				-1 -2 -3 -4
R291	Same as R214				-1 -2 -3 -4
R292	Same as R128				-1 -2 -3 -4
R293	Same as R216				-1 -2 -3 -4
R294	Same as R128				-1 -2 -3 -4
R295	Same as R128				-1 -2 -3 -4
R296	Same as R128				-1 -2 -3 -4
R297	Same as R216				-1 -2 -3 -4
R298	Same as R128				-1 -2 -3 -4
R299	Same as R128				-1 -2 -3 -4
R300	Same as R223				-1 -2 -3 -4
R301	Same as R200				-1 -2 -3 -4
R302	Same as R201				-1 -2 -3 -4
R303	Same as R128				-1 -2 -3 -4
R304	Same as R128				-1 -2 -3 -4
R305	Same as R197				-1 -2 -3 -4
R306	Same as R3				-1 -2 -3 -4
R307	Same as R56				-3 -4
R308	Res, Fxd, 620K, 5%, 1/4W		RL07S624J	202-0624	-3 -4
R309	Res, Fxd, 910 ohm, 5%, 1/4W		RL07S911J	202-0911	-3 -4
R310	Res, Fxd, 150K, 5%, 1/4W		RL07S154J	202-0154	-3 -4
R311	Res, Fxd, 15K, 5%, 1/4W		RL07S153J	202-0153	-3 -4
R312	Res, Fxd, 56 ohm, 5%, 2W (S/N 001-010)		RL42S560J	208-0560	-3 -4
R312	Res, Fxd, 20 ohm, 5%, 5W (S/N 011-UP)	IRC	PW5-20 OHM	224-0073	-3 -4
R313	Same as R312 (S/N 001-010)				-3 -4
R313	Unassigned (S/N 011-UP)				-3 -4
R314	Res, Fxd, 5.1K, 5%, 1/4W		RL07S512J	202-0512	-3 -4
R315	Res, Fxd, 7.5K, 5%, 1/4W		RL07S752J	202-0752	-3 -4
R316	Res, Fxd, 12M, 5%, 1/4W		RL07S126J	202-0126	-3 -4
R317	Same as R56				-3 -4
R318	Same as R56				-3 -4
R319	Same as R56				-3 -4
R320	Res, Fxd, 1.2M, 5%, 1/4W		RL07S125J	202-0125	-3 -4
R321	Res, Fxd, 240 ohm, 5%, 1/4W		RL07S241J	202-0241	-3 -4
R322	Res, Fxd, 620 ohm, 5%, 1/4W		RL07S621J	202-0621	-3 -4
R323	Res, Var, Trimmer, 200 ohms	Bourne	3386P-1-201	244-0087	-3 -4
R324	Same as R132				-1 -2 -3 -4
R326	Res, Var, Trimmer, 10k, 15t	Bourne	3006P-1-103	244-0030	-1 -2 -3 -4
R327	Res, Fxd, 510 ohm, 5%, 1/4W		RL07S511J	202-0511	-2 -4
R328	Res, Var, Trimmer, 10K	Bourne	3386W-1-103	244-0096	-2 -4
R329	Same as R84				-3 -4

## SECTION 7.4: ASE-2 AM STEREO EXCITER ASSEMBLY LIST OF MATERIAL, REF DES PREFIX A1

REF DES	DESCRIPTION	MFR	MFR P/N	DELTA NO.	USED ON:
R330	Res, Fxd, 4.7K, 5%, 1/4W		RL07S472J	202-0472	-3 -4
R331	Res, Fxd, 300 ohm, 5%, 1/4W		RL07S301J	202-0301	-1 -2 -3 -4
R332	Same as R331				-1 -2 -3 -4
R333	Same as R4				-1 -2 -3 -4
R334	Same as R128				-1 -2 -3 -4
R335	Same as R128				-1 -2 -3 -4
R339	Res, Fxd, 330K, 5%, 1/4W		RL07S334J	202-0334	-1 -2 -3 -4
S1	Switch, DIP, 3 x SPDT	CTS	206-123RAST	660-0058	-1 -2 -3 -4
S2	Switch, DIP, 4 x SPDT	CTS	206-124RAST	660-0057	-1 -2 -3 -4
S4	Same as S1				-1 -2 -3 -4
S5	Same as S2				-1 -2 -3 -4
S6	Switch, DIP, SPDT	CTS	206-121RAST	660-0056	-1 -2 -3 -4
T1	Transformer, RF	Coilcraft	D2275	364-0005	-2 -4
TB1	Header, 3 Terminal, for mating plug	Weidmuller	1125.6	616-0080	-1 -2 -3 -4
TB2	Same as TB1				-1 -2 -3 -4
TB3	Same as TB1				-1 -2 -3 -4
U1	IC, Quad Bifet Op Amp		TL074	540-0040	-1 -2 -3 -4
U2	IC, TTL, Quad NOR 50 ohm line driver		74128	500-0128	-1 -2 -3 -4
U3	IC, TTL, Quad EXOR		74LS86	506-0086	-2 -4
U4	IC, TTL, Hex OC Buffer		7406	500-0006	-2 -4
U5	IC, Amplifier, RF	Motorola	MC1733CP	540-0021	-1 -2 -3 -4
U6	IC, Dual Line Receiver		75107A	532-0001	-1 -2 -3 -4
U7	IC, Op Amp, Bifet		TL081CP	540-0027	-3 -4
U8	IC, ECL, Phase/Freq. Det.	Motorola	MC12040P	516-0008	-3 -4
U9	IC, CMOS, Unbuffered Hex Inv		4069UB	524-0069	-1 -2
U10	IC, CMOS, Counter		4040	522-0040	-1 -2
U11	IC, CMOS, Dual 4 Input AND		4082	522-0082	-1 -2
U12	Same as U1				-1 -2 -3 -4
U14	IC, ECL, Triple EXOR	Motorola	MC10107P	516-0009	-3 -4
U15	IC, ECL, Triple Line Rcvr	Motorola	MC10116P	516-0005	-3 -4
U16	IC, Comparator	National	LM311N	540-0011	-3 -4
U17	IC, Amplifier, 50 ohms	Minicircuits	MAR-4	540-0045	-1 -2 -3 -4
U18	Hybrid, two way, zero degree	Minicircuits	PSC-2-1	690-0008	-1 -2 -3 -4
U19	Mixer, Double Balanced	Minicircuits	SBL-3	690-0007	-1 -2 -3 -4
U20	Same as U19				-1 -2 -3 -4
U21	IC, ECL, Dual D Flip-Flop		10131	516-0006	-1 -2 -3 -4
U22	Same as U1				-1 -2 -3 -4
U23	Same as U1				-1 -2 -3 -4
U24	IC, Dual Transconductance Amplifier	National	LM13700N	540-0044	-1 -2 -3 -4
U25	IC, Bifet Op Amp		TL081CP	540-0027	-1 -2 -3 -4
U26	Same as U1				-1 -2 -3 -4
U27	Same as U1				-1 -2 -3 -4
U28	Same as U24				-1 -2 -3 -4
U29	Same as U25				-1 -2 -3 -4
U30	Same as U1				-1 -2 -3 -4
U31	Same as U25				-1 -2 -3 -4
U32	IC, CMOS, PLL		4046B	522-0046	-3 -4
U33	Same as U24				-1 -2 -3 -4
U34	IC, Dual Bifet Op Amp		TL072	540-0039	-1 -2 -3 -4
U35	Same as U1				-1 -2 -3 -4
U36	Same as U1				-1 -2 -3 -4
U37	Same as U24				-1 -2 -3 -4
U38	Same as U34				-1 -2 -3 -4
U39	Same as U1				-1 -2 -3 -4
U40	IC, Op Amp, Dual Bifet		TL072	540-0039	-3 -4
U41	IC, CMOS, Dual D Flip Flop		4013B	522-0013	-3 -4
U42	IC, CMOS, Binary Counter		4040B	522-0040	-3 -4
U43	Same as U34				-1 -2 -3 -4
VR1	IC, Positive Voltage Regulator	National	LM317T	544-0028	-1 -2 -3 -4
VR2	IC, Negative Voltage Regulator	National	LM337T	544-0030	-1 -2 -3 -4
VR3	Same as VR1				-1 -2 -3 -4
VR4	IC, Voltage Regulator, -15V	Motorola	MC7915CT	544-0004-015	-2 -4
VR5	IC, Voltage Regulator, +15V	Motorola	MC7815CT	544-0003-015	-2 -4

## SECTION 7.4: ASE-2 AM STEREO EXCITER ASSEMBLY LIST OF MATERIAL, REF DES PREFIX A1

REF DES	DESCRIPTION	MFR	MFR P/N	DELTA NO.	USED ON:
VR6	IC, Positive Voltage Regulator	National	LM317T	544-0028	-3 -4
VR7	Same as VR6				-2 -4
XU1	Socket, IC, 14 Pin DIP	Amp	2-640357-1	736-0054	-1 -2 -3 -4
XU2	Same as XU1				-1 -2 -3 -4
XU3	Socket, IC, 14 Pin DIP	Amp	2-640357-1	736-0054	-2 -4
XU4	Same as XU3				-2 -4
XU5	Same as XU1				-1 -2 -3 -4
XU6	Same as XU1				-1 -2 -3 -4
XU7	Socket, IC, 8 Pin DIP	Amp	2-640463-1	736-0055	-3 -4
XU8	Socket, IC, 14 Pin DIP	Amp	2-640357-1	736-0054	-3 -4
XU9	Same as XU1				-1 -2 -3 -4
XU10	Socket, IC, 16 Pin DIP	Amp	2-640358-1	736-0056	-1 -2 -3 -4
XU11	Same as XU1				-1 -2 -3 -4
XU12	Same as XU1				-1 -2 -3 -4
XU14	Socket, IC, 16 Pin DIP	Amp	2-640358-1	736-0056	-3 -4
XU15	Same as XU14				-3 -4
XU16	Same as XU7				-3 -4
XU21	Same as XU10				-1 -2 -3 -4
XU22	Same as XU1				-1 -2 -3 -4
XU23	Same as XU1				-1 -2 -3 -4
XU24	Same as XU10				-1 -2 -3 -4
XU25	Socket, IC, 8 Pin DIP	Amp	2-640463-1	736-0055	-1 -2 -3 -4
XU26	Same as XU1				-1 -2 -3 -4
XU27	Same as XU1				-1 -2 -3 -4
XU28	Same as XU10				-1 -2 -3 -4
XU29	Same as XU25				-1 -2 -3 -4
XU30	Same as XU1				-1 -2 -3 -4
XU31	Same as XU25				-1 -2 -3 -4
XU32	Same as XU14				-3 -4
XU33	Same as XU10				-1 -2 -3 -4
XU34	Same as XU25				-1 -2 -3 -4
XU35	Same as XU1				-1 -2 -3 -4
XU36	Same as XU1				-1 -2 -3 -4
XU37	Same as XU10				-1 -2 -3 -4
XU38	Same as XU25				-1 -2 -3 -4
XU39	Same as XU1				-1 -2 -3 -4
XU40	Same as XU7				-3 -4
XU41	Same as XU8				-3 -4
XU42	Same as XU14				-3 -4
XU43	Same as XU25				-1 -2 -3 -4
XY1	Socket, Component, 0.036-0.051 pin	Amp	1-380758-0	736-0043	-1 -2 -3 -4
XY2	Same as XY1				-1 -2 -3 -4
Y1	Crystal, 4 times carrier	Delta	D05-110-XX	005-0110-XXX	-1 -2 -3 -4
Y2	Crystal, Watch, 32768 Hz	Q-Matics		624-0017	-1 -2 -3 -4

**APPENDIX A**

**A VECTOR APPROACH TO C-QUAM®**

## APPENDIX A

### A VECTOR APPROACH TO C-QUAM<sup>•</sup>

#### INTRODUCTION:

In order for C-QUAM (compatible quadrature amplitude modulation) to be successful, members of the broadcast community need a clear, intuitive understanding of C-QUAM fundamentals. To this end, a graphical approach to C-QUAM is presented in this article with the hope of clearing up any uncertainty, confusion or mystery about C-QUAM. Additionally, this approach is useful in understanding some of the factors that limit C-QUAM stereo performance in the real world and the steps necessary to reduce these limiting factors.

#### A VECTOR MODEL OF MODULATION:

The following is a brief description of the vector model of modulation for readers who are unfamiliar with the concept.

It can be shown mathematically that an RF carrier may be plotted on the complex plane as a vector rotating counterclockwise at the carrier frequency,  $\omega_c$  radians per second, as shown in Figure 1. The magnitude of the carrier has been normalized. That is, the magnitude of all vectors discussed in the remainder of this article are divided by the magnitude of the carrier vector. The angle that the vector makes with the real axis,  $P$ , is  $\omega_c t$  radians assuming that the carrier vector passed the real axis at  $t=0$ .

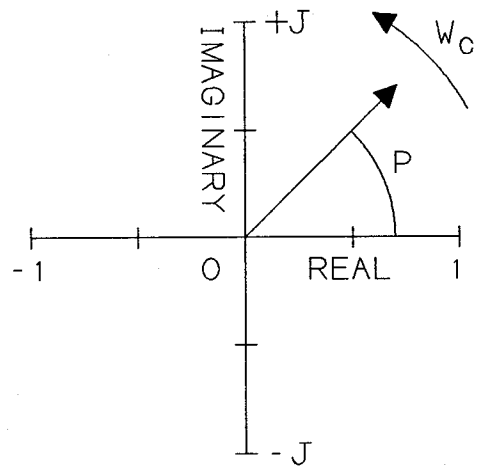


Figure 1

Now we rotate the complex plane about the origin (O) so that the real axis is vertical. As the vector rotates and aligns with the real axis, we lock onto the vector by rotating the complex plane at the carrier rate. Thus, if we climb aboard the complex plane, we will see the carrier vector stationary and aligned with the real axis as shown in Figure 2. Notice that we have reversed the imaginary axis so that increasing angles are clockwise in accordance with the usual convention in modulation theory.

The carrier vector now has an angle of zero degrees with the real axis establishing a phase reference. Vectors that lie along the real axis are in-phase with the carrier and are sometimes called I vectors. The real axis may therefore be relabeled the I axis as shown in Figure 2. A vector pointing to the right along the imaginary axis (now shown) would lead the carrier vector by ninety

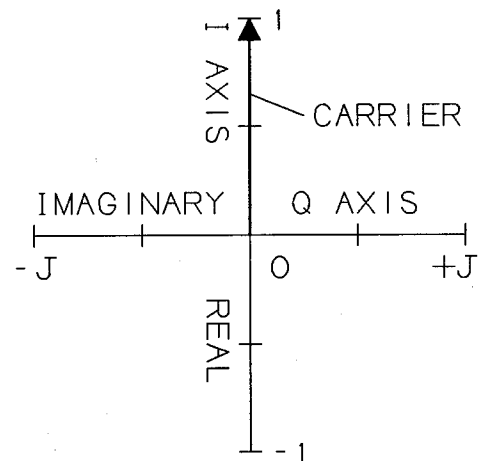


Figure 2

<sup>•</sup> C-QUAM is a registered trademark of Motorola, Inc.

degrees while a vector pointing to the left along the imaginary axis would lag behind the carrier by ninety degrees. Vectors along the imaginary axis are said to be "in quadrature" with the carrier and are sometimes called Q vectors. The imaginary axis is relabeled the Q axis as shown in Figure 2.

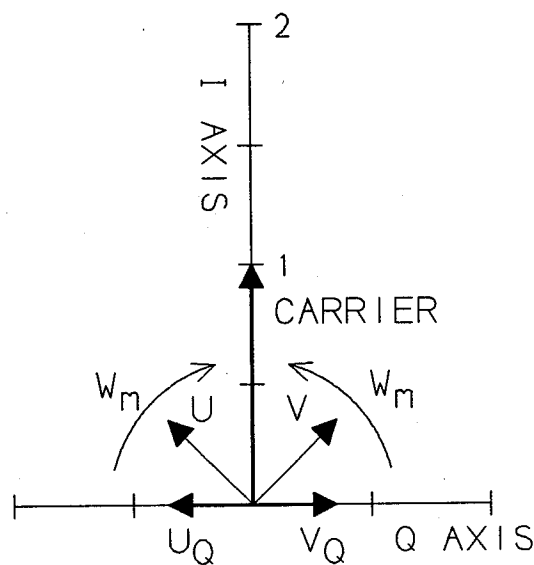


Figure 3a

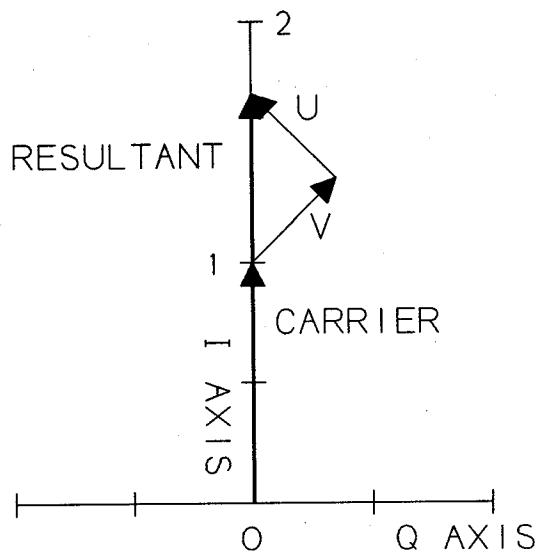


Figure 3b

Now add two vectors U and V of equal magnitude at frequencies  $W_c + W_m$  and  $W_c - W_m$  respectively as shown in Figure 3a. Since our reference axis is already rotating at  $W_c$ , the U vector will rotate counterclockwise at a frequency  $W_c + W_m - W_c = W_m$ . Similarly, vector V will rotate at a frequency of  $W_c - W_m - W_c = -W_m$  or clockwise at  $W_m$ . Notice that vectors U and V are arranged so that as they rotate, the angle of U to the reference is equal and opposite to the angle of V. The quadrature components of vectors U and V,  $U_Q$  and  $V_Q$ , respectively in Figure 3a, are equal in magnitude and in opposite directions. If we add vectors U and V to the carrier vector as shown in Figure 3b,  $U_Q$  will always cancel  $V_Q$  and the resultant will be a stretched or compressed version of the carrier vector. This is called amplitude modulation (AM) and U and V are called the upper and lower sidebands respectively.

When broadcasting stereo source material in monophonic AM, the left and right audio channels are summed (L+R) and fed to the transmitter modulator so that the resultant vector of Figure 3b has a magnitude equal to  $1+L+R$ . Figure 3b shows the ideal case for single tone amplitude modulation. If, however,  $U_Q$  does not exactly cancel  $V_Q$ , the resultant vector of Figure 3b will be slightly tilted away from the in-phase axis. This effect is called incidental phase modulation (IPM).

Now reorient the U and V vectors so that they maintain equal and opposite angles with the quadrature axis as shown in Figure 4. For clarity, the carrier vector has been omitted. The components of U and V along the in-phase axis, labeled  $U_I$  and  $V_I$ , are equal in magnitude and in opposite direction. If vectors U and V are added,  $U_I$  will exactly cancel  $V_I$  so that the magnitude of the carrier vector (not shown) is unaffected. The resultant of U and V extends only along the quadrature axis always maintaining a plus or minus ninety degree phase angle with the carrier vector.

This vector can be generated by a balanced modulator driven by a carrier frequency signal at minus ninety degrees phase angle to the carrier signal and by an audio signal at frequency  $W_m$ . The modulator output is a double sideband suppressed carrier signal where U is the upper sideband and V is the lower sideband. In generating C-QUAM, the audio signal to the balanced modulator is left channel minus right channel audio (L-R). During monophonic modulation,  $L-R=0$  and the resultant vector of Figure 4 disappears.

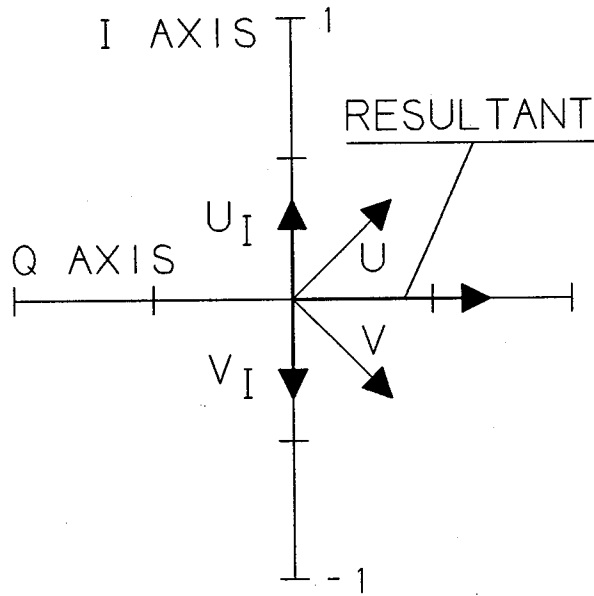


Figure 4

For the remainder of this article, the contra-rotating vectors U and V will not be shown. Instead, only the resultant vectors of Figure 3b and Figure 4 along the in-phase and quadrature axes will be shown.

**QUADRATURE AMPLITUDE MODULATION:**

If the resultant vectors of Figure 3b and Figure 4 are combined as shown in Figure 5, the in-phase vector which is  $1+L+R$  long adds with the quadrature vector which is  $L-R$  long to form quadrature amplitude modulation or QUAM. This is stereo modulation since it contains both  $L+R$  and  $L-R$  information.

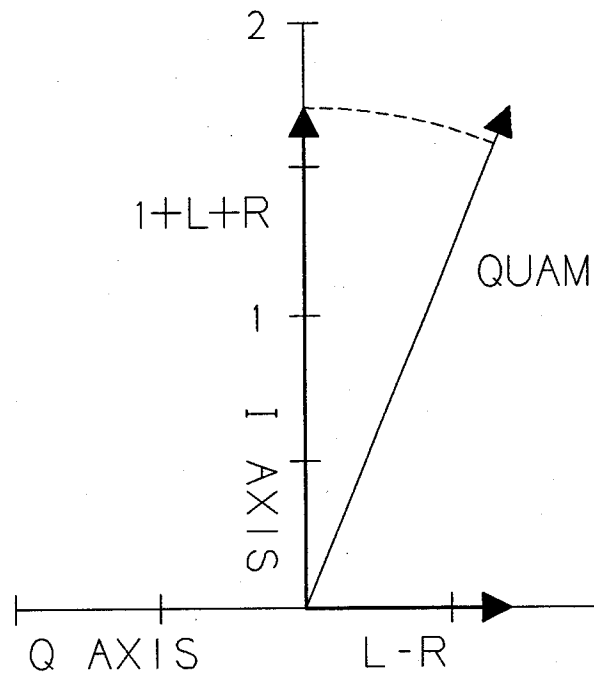


Figure 5

**COMPATIBLE QUADRATURE AMPLITUDE MODULATION:**

Unfortunately, QUAM has one drawback for stereo transmission; it is not compatible with the envelope detectors in existing monophonic receivers. The QUAM vector is longer than the I vector ( $1+L+R$ ) so an envelope detector will have too large an output. The solution to the compatibility problem is fairly obvious - shorten the QUAM vector until it is the same length as the I vector as shown in Figure 6. This shorter vector is called compatible quadrature amplitude modulation or C-QUAM.

Inspection of Figure 6 reveals that the C-QUAM vector is just a phase modulated I vector. C-QUAM is generated by feeding a QUAM signal to an RF limiter to produce a phase modulated carrier. This carrier replaces the crystal oscillator in the broadcast transmitter. An  $L+R$  audio signal

is fed (input) to the transmitter modulator exactly as in monophonic transmission. The transmitter output is C-QUAM.

Clearly, however, the transmitter output may not be perfect C-QUAM since the C-QUAM vector's direction may be shifted from its ideal phase angle by IPM and its length may be affected by the transmitter's audio response, hum, noise, distortion and incidental AM. The total transmission system response to these errors must be evaluated at the output of the stereo decoder, a modulation monitor or radio receiver.

In the decoding process, the C-QUAM signal is stretched back to a QUAM signal and  $1+L+R$  and  $L-R$  audio signals are recovered using synchronous detectors. A block diagram of this decoding scheme is shown in Figure 7. The C-QUAM vector is stretched by a variable gain RF amplifier in a feedback loop. The C-QUAM signal is envelope detected to produce a reference signal for comparison to the I synchronous detector output. The envelope detector output is proportional to the length of the C-QUAM vector and the I synchronous detector output is proportional to the I component of the amplifier output. The amplifier gain is adjusted by the feedback loop so that the I synchronous detector output equals the C-QUAM envelope detector output. This can only occur when the amplifier output is the desired QUAM signal.

The effects of the above mentioned transmission errors can now be examined in light of the decoding model.

**EFFECTS OF IPM:**

Experience has shown that the greatest limiting factor to the channel separation performance of C-QUAM is incidental phase modulation in the transmitter. This causes the C-QUAM vector to tilt from its proper phase angle as shown in Figure 8. The recovered  $1+L+R$  (monophonic) audio is still correct since the length of the C-QUAM vector is unaffected by IPM. However, the IPM has caused decoding of quadrature vector  $Q'$  instead of the correct length vector,  $Q$ . The resulting error in the recovered  $L-R$  audio degrades stereo channel separation.

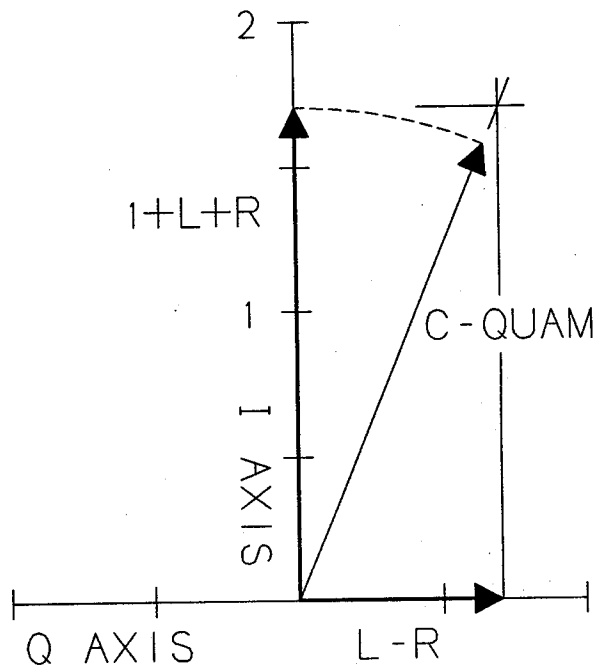


Figure 6

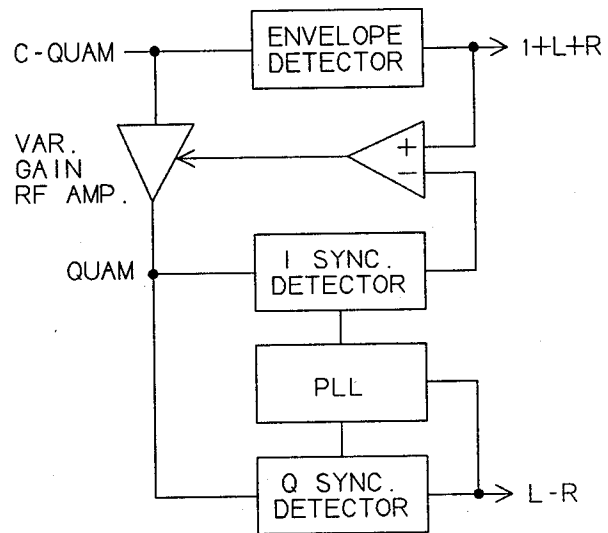


Figure 7



As a rule of thumb, the maximum channel separation is equal to the main channel ( $L+R$ ) to subchannel ( $L-R$ ) crosstalk. That is, if the transmitter is modulated at 50% 1 kHz AM ( $L=R=0.25$ ) and the recovered  $L-R$  audio is  $X$  dB below the level of the recovered  $L+R$  audio, the best channel separation attainable is  $X$  dB at 1 kHz  $L$  or  $R=0.5$ .

Main channel to subchannel crosstalk is a convenient method of evaluating transmitter performance since the  $L-R$  reading of the modulation monitor is an indication of the level of IPM. Typical subchannel readings for broadcast transmitters in monophonic service are from 15 to 25 dB below the main channel. To improve separation, the transmitter IPM must be reduced to a tolerable level. The  $L-R$  readings can usually be improved to less than -30 dB and sometimes less than -40 dB by neutralization and additional power supply filtering.

#### AMPLITUDE ERROR:

The next most important factor in separation performance is the accuracy of the length of the C-QUAM vector. The major factor effecting this length is the frequency response of the transmitter modulator. Figure 9 shows a shortened C-QUAM vector which would typically occur as a result of high frequency roll off in the transmitter modulator. The decoder's synchronous detectors see the  $I'$  and  $Q'$  vectors instead of the  $I$  and  $Q$  vectors. The  $I'$  and  $Q'$  vectors are proportionally shortened versions of the  $I$  and  $Q$  vectors so that the decoded  $1+L+R$  and  $L-R$  audio signals are also proportionally reduced. However, when the  $1$  is subtracted from the shortened  $1+L+R$  signal, the remaining  $L+R$  audio is reduced by more than the proportion that the  $L-R$  audio is reduced. Thus, separation is degraded.

Figure 10 illustrates a method for correcting separation loss due to transmitter audio response roll-off. The line at 45 degrees to the in-phase axis is the path traced by the tip of the QUAM vector for left channel only

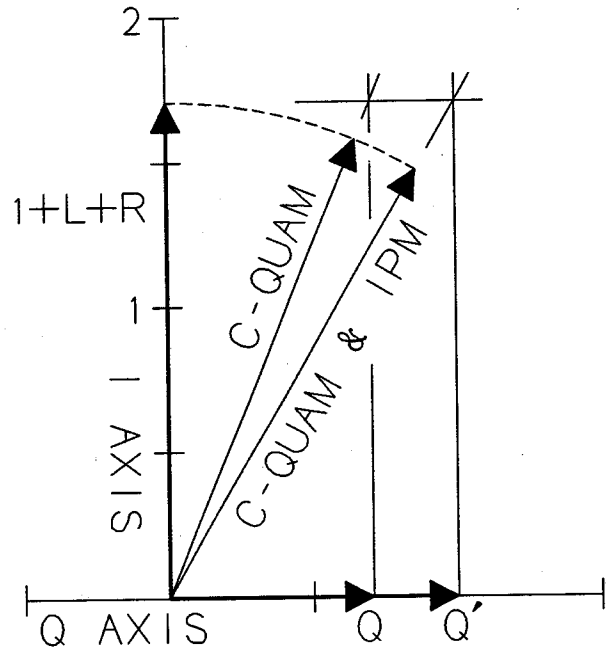


Figure 8

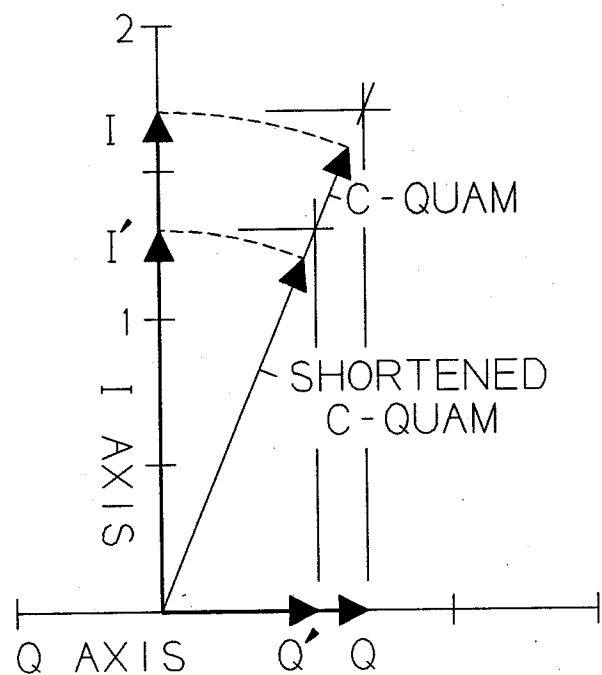


Figure 9

modulation ( $R=0$ ). Thus, for perfect separation under left only conditions, any C-QUAM vector must be stretched to this line by the variable gain amplifier in the decoding circuit. Figure 10 shows the desired C-QUAM vector and its shortened version reduced by 6 dB. Without changing phase angle, this vector would be stretched to point X well off the line. If, however, the phase angle is reduced as shown so that  $Q'$  is further reduced to  $Q^*$ , perfect separation is restored.

The reduction in phase modulation is accomplished by equalizing filters ahead of the phase determining circuits in the exciter. To the extent that these equalizing filters can track the transmitter audio response roll-off, high separation is maintained.

Incidental amplitude modulation (IAM) is another source of error in the length of the C-QUAM vector. The degree of IAM is checked by modulating at  $L=-R=0.5$  (100% L-R). The transmitter output should be pure phase modulation with no amplitude variation. Any recovered L+R signal is due to IAM. If the level of IAM is not well below the level of IPM, a mis-tuned high Q circuit in a low level RF stage is the likely source of the IAM.

Distortion, hum and noise place a limit on the system separation performance. If the transmitter meets the FCC hum and noise rules, distortion will be the predominant limiting factor unless it is exceptionally low. The distortion products of the transmitter modulator appear added to or subtracted from the C-QUAM vector. The distortion component in the decoded L+R signal is different than the distortion component decoded in the L-R signal for reasons given above. Therefore, the distortion components will not cancel in the dematrixing to left and right audio and distortion products will appear in both channels.

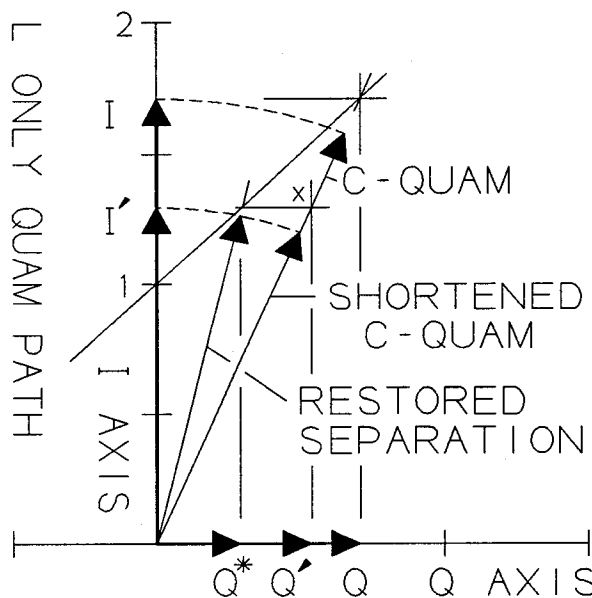


Figure 10

When making single channel separation measurement, distortion products will appear in the decoded output of the undriven channel. Since neither the stereo modulation monitor nor conventional test equipment use frequency selective detectors to measure separation, these distortion products will appear as an equivalent separation loss.

## CONCLUSION:

Use of the vector modulation model leads to understanding of C-QUAM stereo encoding and decoding, the factors that affect stereo system performance, and the steps necessary to control these factors. With proper installation by experienced personnel, these factors are well controlled, yielding excellent stereo performance.

